

SYMBOL	REVISIONS	DATE	ENG
A	INITIAL RELEASE	5/26/04	ESA
B	ADD $\varnothing 1/4"$ ROD LOOPS	10-Sep-04	ESA
C	MOVE TRANSOM GATE LOOP TO BACK SIDE	11/4/04	JTM
D	CHANGE SEAT HEIGHT AND OVERALL HEIGHT MODIFY UPPER RAIL AND GATE LOOP	3/18/05	JTM
E	REMOVE ALL-THREAD AND 3/16" PLATE REPLACE WITH STANDARD $\varnothing 2 1/2" \times 1/8"$ ROUND PLATE	30-Aug-06	ESA

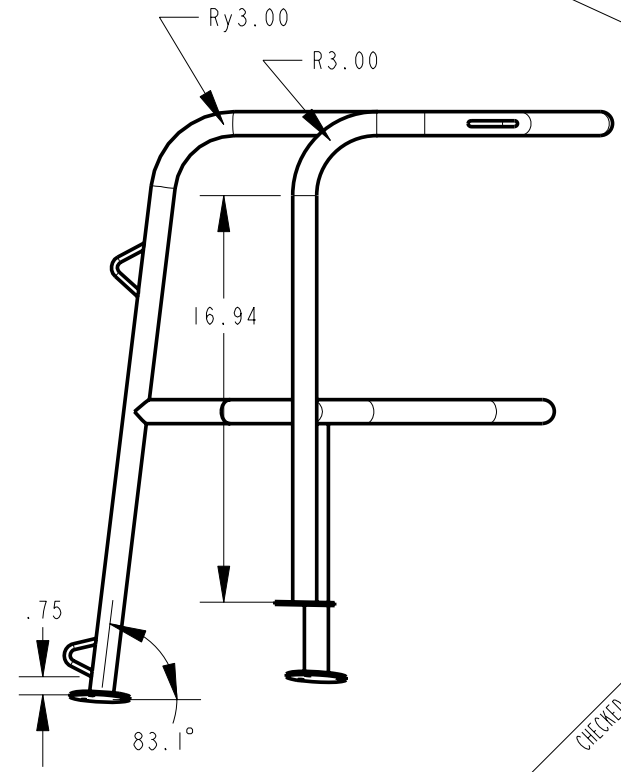

STERNRAIL SEAT TUBING
 NOTES: SCALE=0.125
 1. MATERIAL: STAINLESS STEEL
 2. ALL DIMENSIONS ARE INCHES AND DEGREES
 3. ALL WELDS TO MEET AWS STANDARDS.
 4. BREAK AND DEBURR ALL EDGES
 5. BRIGHT POLISH AFTER FABRICATION
 QTY: 1 PER BOAT AND 1 MIRROR IMAGE PER BOAT

PROPRIETARY INFORMATION: THIS DRAWING CONTAINS INFORMATION FOR WHICH HUNTER MARINE CORPORATION HAS PROPRIETARY RIGHTS.

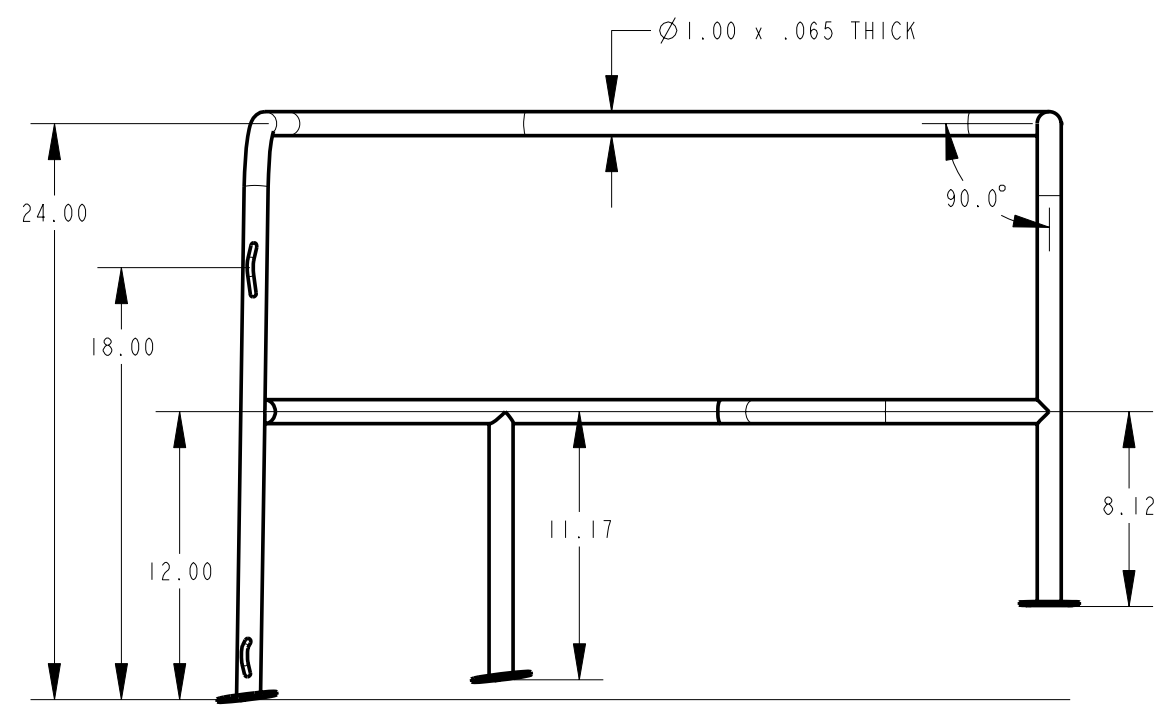
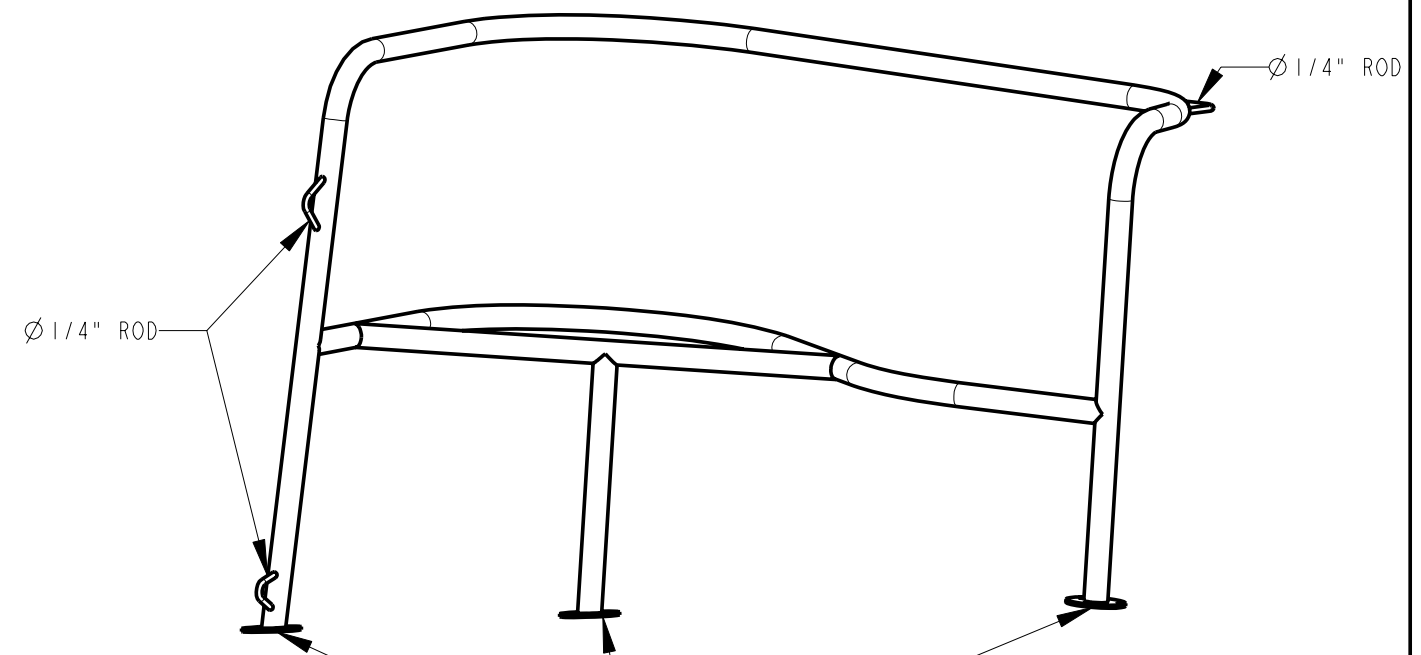
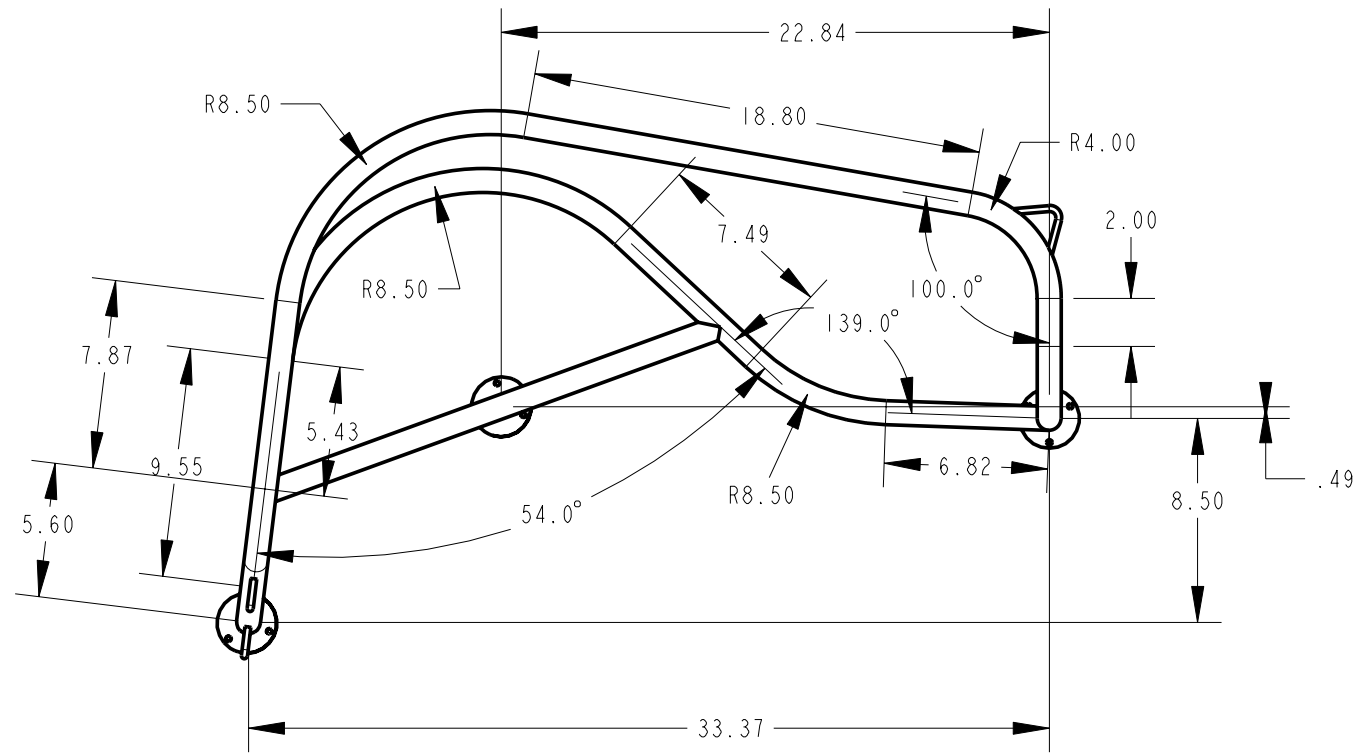

DRAWING TITLE: STERNRAIL SEAT TUBING			
DRAWN BY: JTM	DATE: 26-May-04	SHEET 1	OF 1
SCALE: 0.125	HUNTER PART NO. TBD	REVISION A	DRAW # 27.STERNRAIL.SEAT.TUBING

CHECKED: