

356 MOORING CLEATS INSTALLATION

PAGE 33

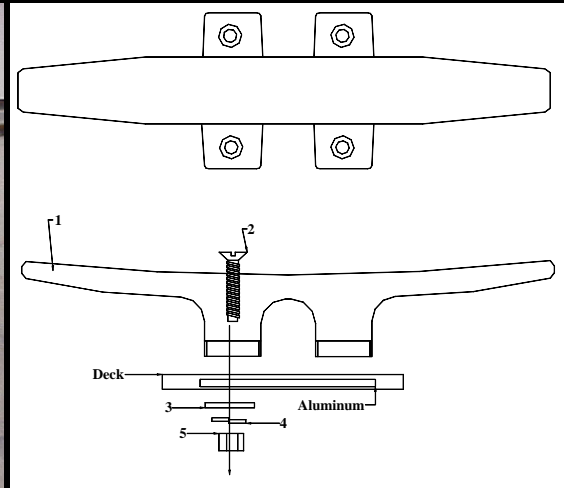

#	#Ea.	Description	Size	Part#
1	7	Cleats	8" 4 Hole	
2	28	Cleat Screws	1/4-20 x 2" F/H	462030
3	28	Fender Washer	1/4"	469110
4	28	Lock Washer	1/4"	469470



1. Seven mooring cleats will go on the deck, three on each side and one in the anchorwell.
2. Use the fiberglass splash to mark the mounting hole locations for each cleat.
3. Drill thru these locations with a 13/64 drill bit then tap with a 1/4"-20 tap.
4. Dremel the holes to expose raw edge of glass (only the edges of the holes).
5. Clean all the surfaces and hardware with alcohol.
6. Caulk the mounting holes with designated caulk (See Page 1 #3).
7. Secure the cleats to the deck with designated fasteners (including fender washers , lock washers and hex nuts).
8. Clean up excess caulk using alcohol.

Revision Dates:

Expected Time: 40 min.