

SYMBOL	REVISIONS	DATE	ENG
C	REMOVE PLATE & HOLES	10/6/05	BMB

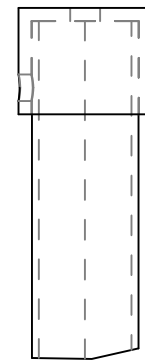
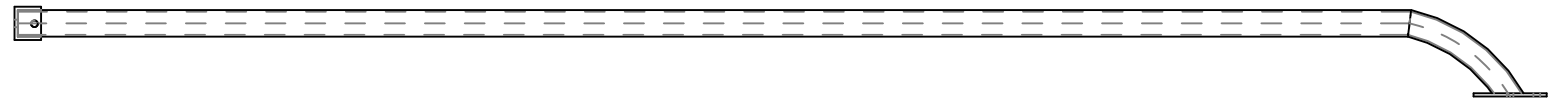
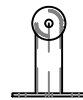
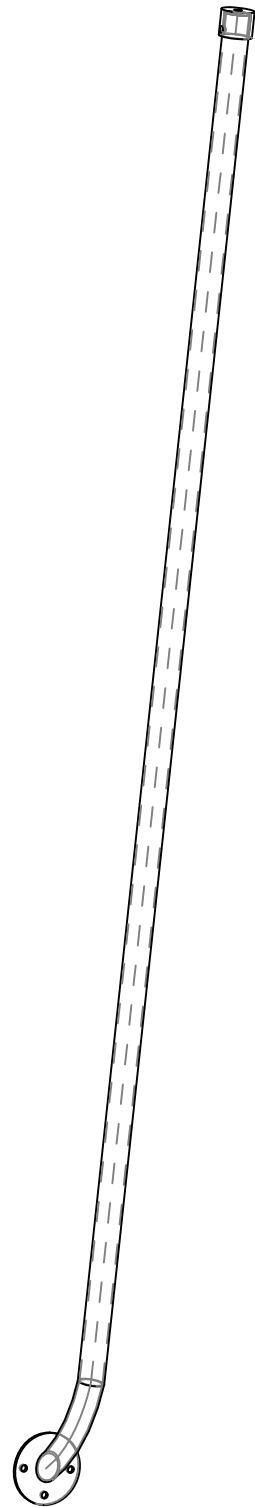

SCALE 0.500

BOATS
38
41
44

PROPRIETARY INFORMATION: THIS DRAWING CONTAINS INFORMATION FOR WHICH HUNTER MARINE CORPORATION HAS PROPRIETARY RIGHTS.



DRAWING TITLE:  
COMPANIONWAY GRABRAIL ASSY

DRAWN BY: BMB	DATE: 05-Oct-05	SHEET 1	OF 3
SCALE: 0.125	HUNTER PART NO. TBD	REVISION -	DRAW # COMPANIONWAY GRABRAIL ASSY

CHECKED:

SYMBOL	REVISIONS	DATE	ENG
C	REMOVE SCREW HOLES	10/6/05	BMB

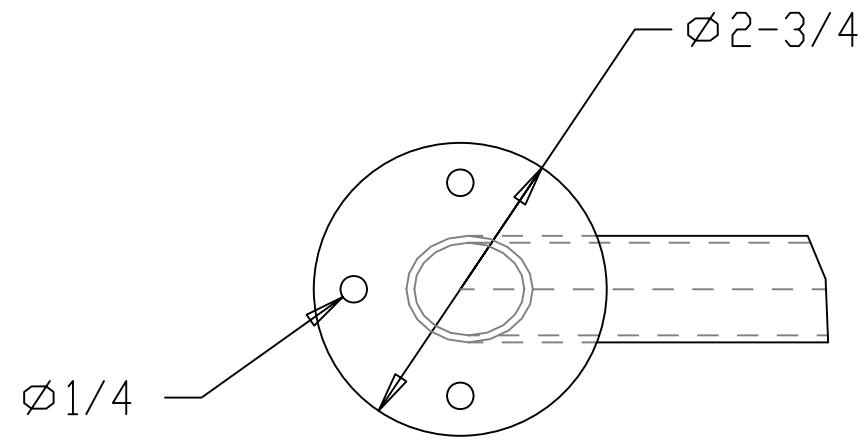
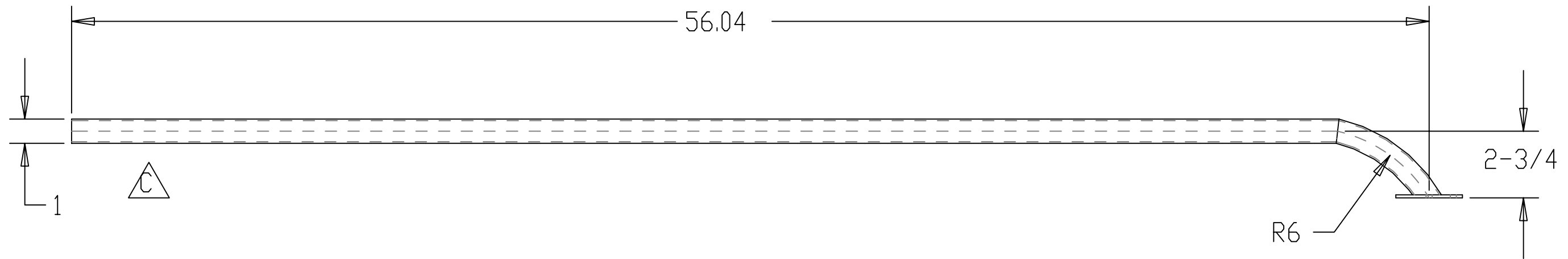

SCALE 0.500

COMPANIONWAY GRABRAIL

NOTES: SCALE= 0.125

1. MATERIAL: 1" x 0.065 WALL TUBE
2. ALL DIMENSIONS ARE INCHES AND DEGREES
3. ALL WELDS TO MEET AWS STANDARDS.
4. BREAK AND DEBURR ALL EDGES
5. BRIGHT POLISH AFTER FABRICATION

PROPRIETARY INFORMATION: THIS DRAWING CONTAINS INFORMATION FOR WHICH HUNTER MARINE CORPORATION HAS PROPRIETARY RIGHTS.



H U N T E R C O M

DRAWING TITLE: <i>COMPANIONWAY GRABRAIL</i>			
DRAWN BY: <i>ENG</i>	DATE: <i>05-Oct-05</i>	SHEET <i>2</i>	OF <i>3</i>
SCALE: <i>0.125</i>	HUNTER PART NO. <i>TBD</i>	REVISION <i>-</i>	DRAW # <i>COMPANIONWAY GRABRAIL ASSY</i>

CHECKED:

SYMBOL	REVISIONS	DATE	ENG
C	REMOVE PLATE	10/6/05	BMB

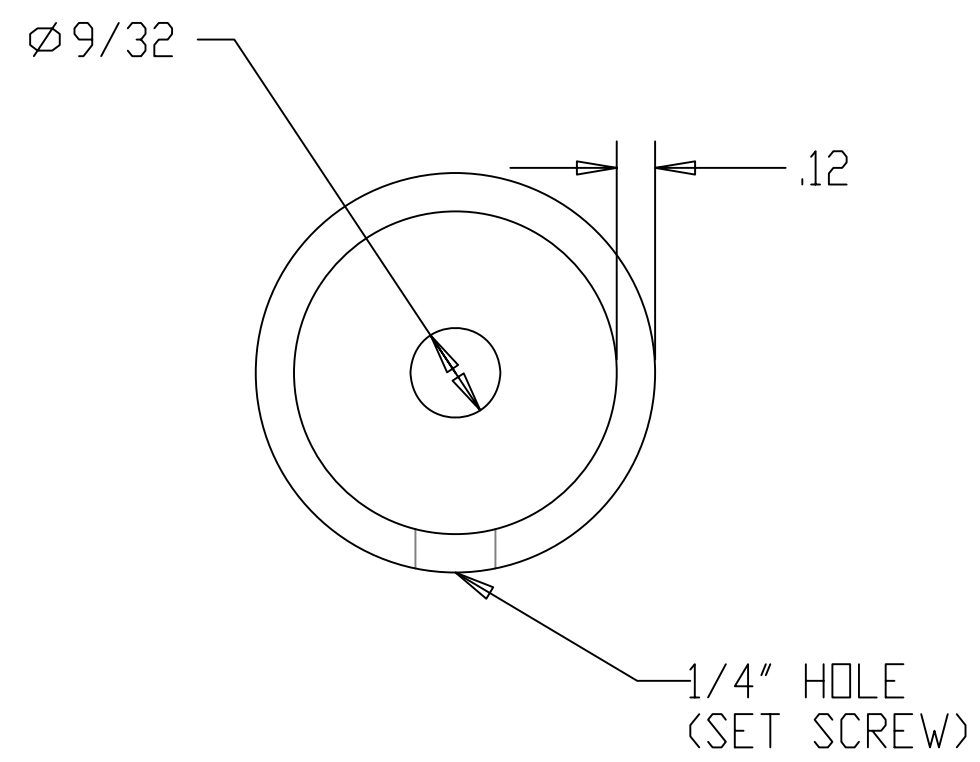
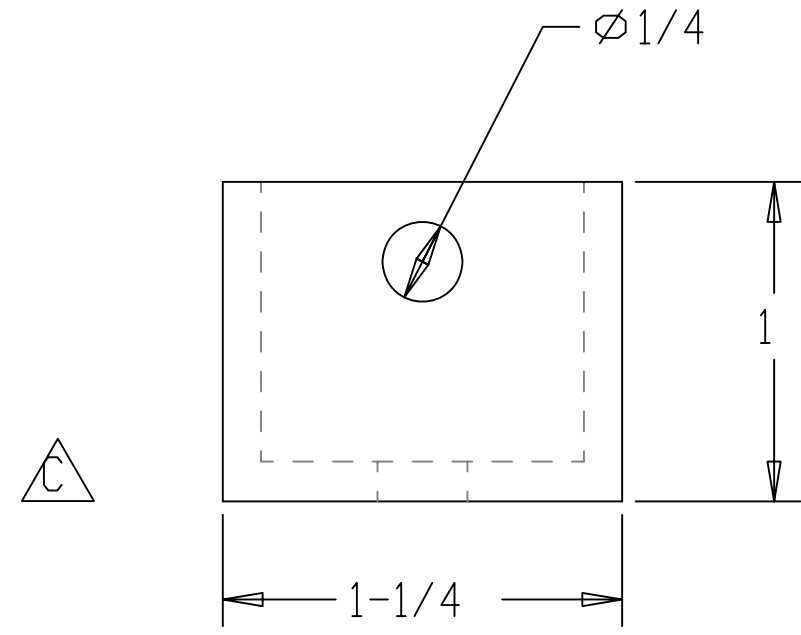

COMPANIONWAY GRABRAIL

NOTES: SCALE= 0.125

1. MATERIAL: 1 1/4" S.S. TUBING X 0.120 WALL
2. ALL DIMENSIONS ARE INCHES AND DEGREES
3. ALL WELDS TO MEET AWS STANDARDS.
4. BREAK AND DEBURR ALL EDGES
5. BRIGHT POLISH AFTER FABRICATION

PROPRIETARY INFORMATION: THIS DRAWING CONTAINS INFORMATION FOR WHICH HUNTER MARINE CORPORATION HAS PROPRIETARY RIGHTS.			
 <span style="font-size: 2em; font-weight: bold; letter-spacing: 0.5em;">HUNTER</span> <i>COM</i>			
DRAWING TITLE: <i>GRABRAIL SOCKET CUP</i>			
DRAWN BY: <i>BMB</i>	DATE: <i>05-Oct-05</i>	SHEET <i>3</i>	OF <i>3</i>
SCALE: <i>0.063</i>	HUNTER PART NO. <i>TBD</i>	REVISION <i>A</i>	DRAW # <i>COMPANIONWAY GRABRAIL ASSY</i>

CHECKED: