

27

SCHEMATICS

12/1/2005

INDEX

PAGE

3. *AC Panel*
4. *AC Panel Schematic*
5. *AC Wire Kit*
6. *Stage Wire Kits*
7. *Fire Extinguisher Option Kit*
8. *High Water Pump Option Kit*
9. *Battery Switch Panel*
10. *Battery Switch Panel Schematic*
11. *Std DC Panel*
12. *Std DC Panel Schematic*
13. *Deluxe DC Panel*
14. *Deluxe DC Panel Schematic*
15. *DC Panel Connectors*
16. *Hull Harness*
17. *Hull Harness Wire List*
18. *Deck Harness*
19. *Optional Deluxe Deck Harness*
20. *Deck Harness Wire List*
21. *Auto Fire System Schematic*
22. *High Water Pump System Schematic*

| SYMBOL | REVISIONS | DATE | ENG |
|--------|-----------|------|-----|
| | | | |

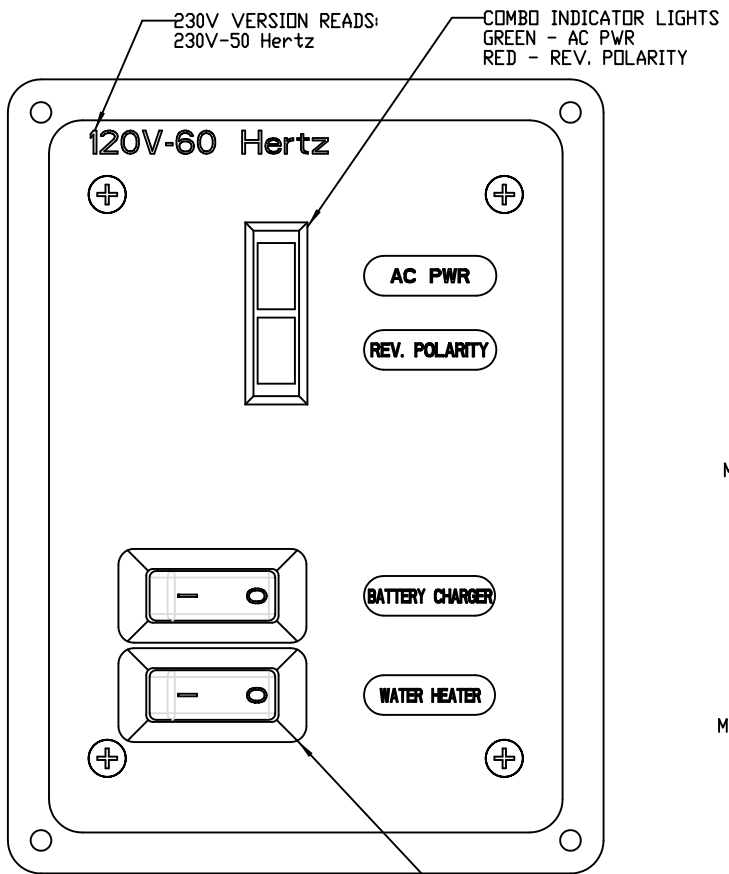

FRONT VIEW

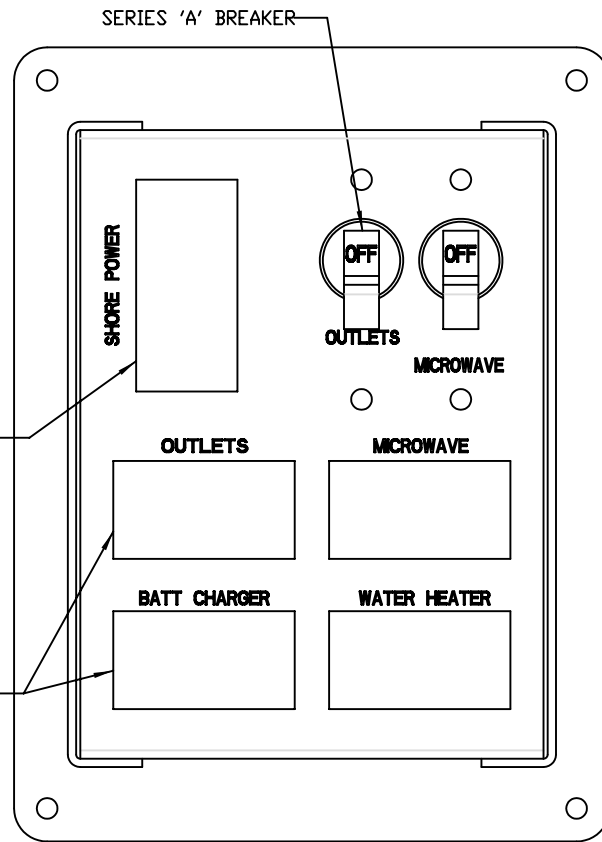

BACK VIEW

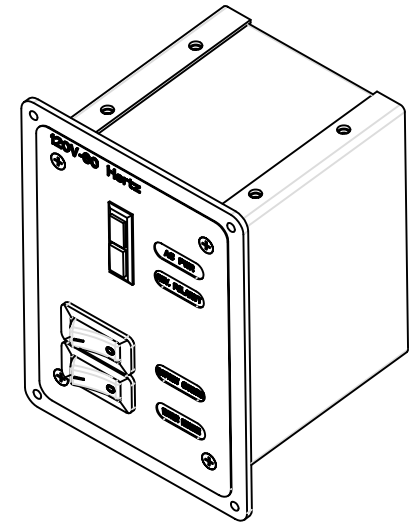

PROPRIETARY INFORMATION THIS DRAWING CONTAINS INFORMATION FOR WHICH HUNTER MARINE CORPORATION HAS PROPRIETARY RIGHTS

| | | | |
|---|-----------------|----------|--------------|
|  HUNTER | | 27 | |
| DRAWING TITLE: | | | |
| PANEL, AC 120V OR 230V | | | |
| DRAWN BY: | DATE: | SHEET | OF |
| JLK | 07-Jun-04 | 2 | 4 |
| SCALE: | HUNTER PART NDL | REVISION | DRAW # |
| 1.000 | TBD | | H27 PANEL AC |

CHECKED

LEGEND:

- * = 16-14 CAPTIVE SPADE #8
- * = 12-10 CAPTIVE SPADE #8
- * = 16-14 RING TERM. #10
- * = 12-10 RING TERM. #10
- * = 12-10 RING TERM. 1/4"

NOTE: CONDUIT ALL HARNESSES COMPLETELY

REV. 10-5-05

27 AC WIRES

P/N 1006242

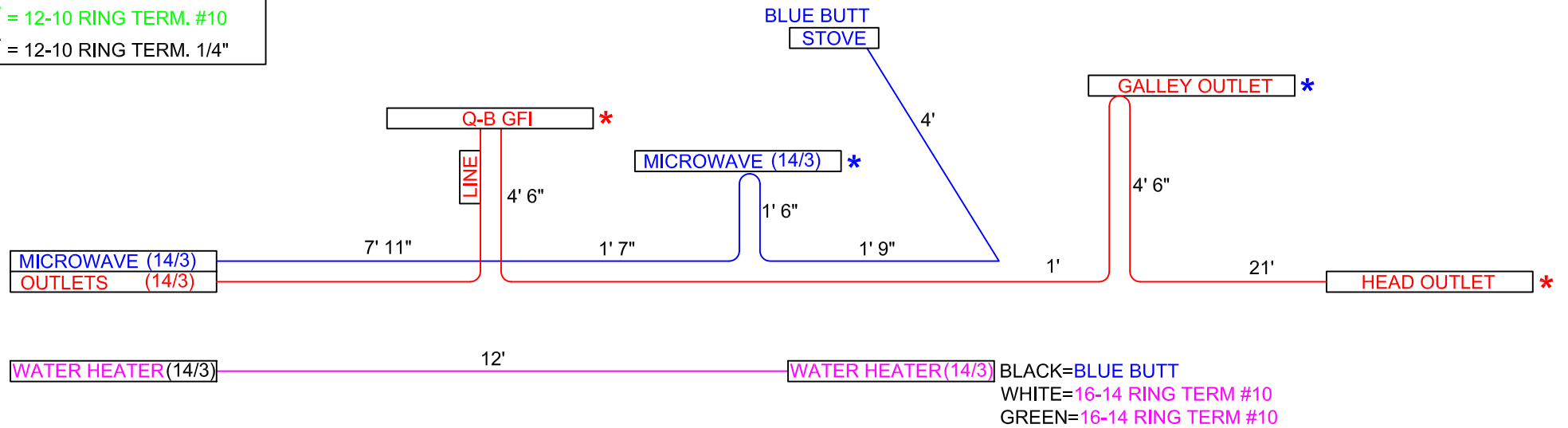

MICROWAVE(14/3) = 18' 3"
 OUTLETS(14/3) = 51' 3"
 WATER HEATER(14/3) = 12'

| STAGE 24A-MODULE P/N 1006239 | | | | | | |
|---|-----------|--------------|--------|----------|---------|----------------------|
| | WIRE SIZE | COLOR | LENGTH | EYE | EYE | DESCRIPTION |
| GNDS | 6 GA | GREEN/YELLOW | 14' | 1/2" | 1/4" | CHAINPLATE PORT |
| | 6 GA | GREEN/YELLOW | 10' | 1/2" | 1/4" | CHAINPLATE STBD |
| | 10 GA | GREEN/YELLOW | 20' | | | FUEL FILL GRD |
| | 4 GA | GREEN/YELLOW | 1' 8" | 1/4" | 1/4" | MAST POST TO KEEL |
| | | | | | | |
| FUEL GAUGE | 16 GA | PINK | 9' | | | FUEL SENSOR (S) |
| | 16 GA | YELLOW | 9' | | | FUEL SENSOR (-) |
| | | | | | | |
| STAGE 24A-DELUXE KIT P/N 1013292 | | | | | | |
| | WIRE SIZE | COLOR | LENGTH | EYE | EYE | DESCRIPTION |
| VHF RADIO | RG-8X | COAX | 22' | M-PL259 | F-PL259 | VHF ANTENNA |
| | | | | | | |
| | | | | | | |
| STAGE 26-ENGINE STAGE KIT P/N 1013325 | | | | | | |
| | WIRE SIZE | COLOR | LENGTH | EYE | EYE | DESCRIPTION |
| HOUSE BATTERY #1 | 2 GA | RED | 8' | 3/8" | PP120-R | BATTERY #1 TO SWITCH |
| | 2 GA | YELLOW | 8' | 5/16" | 5/16" | BATTERY TO NEG |
| | | | | | | |
| YANMAR STARTER | 2 GA | RED | 5' | 5/16" | PP120-W | START TO STUD-YAN |
| | 2 GA | YELLOW | 6' | 5/16" | 3/8" | ENGINE TO GND-YAN |
| | | | | | | |
| FUEL GAUGE | 16 GA | RED | 2' | | | FUEL GAUGE POWER |
| | 16 GA | YELLOW | 2' | | | FUEL GAUGE NEG |
| | 16 GA | BLUE | 2' | | | FUEL GAUGE LIGHT |
| | | | | | | |
| GNDS | 6 GA | GREEN/YELLOW | 25' | 1/4" | 1/2" | PEDESTAL GND |
| | | | | | | |
| STAGE 26-ENGINE DELUXE KIT P/N 1013326 | | | | | | |
| | WIRE SIZE | COLOR | LENGTH | EYE | EYE | DESCRIPTION |
| BATTERY CHARGER | 14/3 | ROMEX | 30" | #8 C. SP | | BATTERY CHARGER |
| | 10 GA | ORANGE/GREEN | 24" | #8 C. SP | #10 | BATTERY #1 |
| | 10 GA | ORANGE/RED | 24" | #8 C. SP | #10 | BATTERY #2 |
| | 10 GA | YELLOW | 24" | #8 C. SP | 1/4" | NEGATIVE |
| | | | | | | |
| STAGE 26-OPTIONS | | | | | | |
| | WIRE SIZE | COLOR | LENGTH | EYE | EYE | DESCRIPTION |
| HOUSE BATTERY #2 | 2 GA | RED | 10' | 3/8" | PP120-R | BATTERY #2 TO SWITCH |
| P/N 1013293 | 2 GA | YELLOW | 2' 6" | 5/16" | 5/16" | BATTERY TO BATTERY |
| | | | | | | |

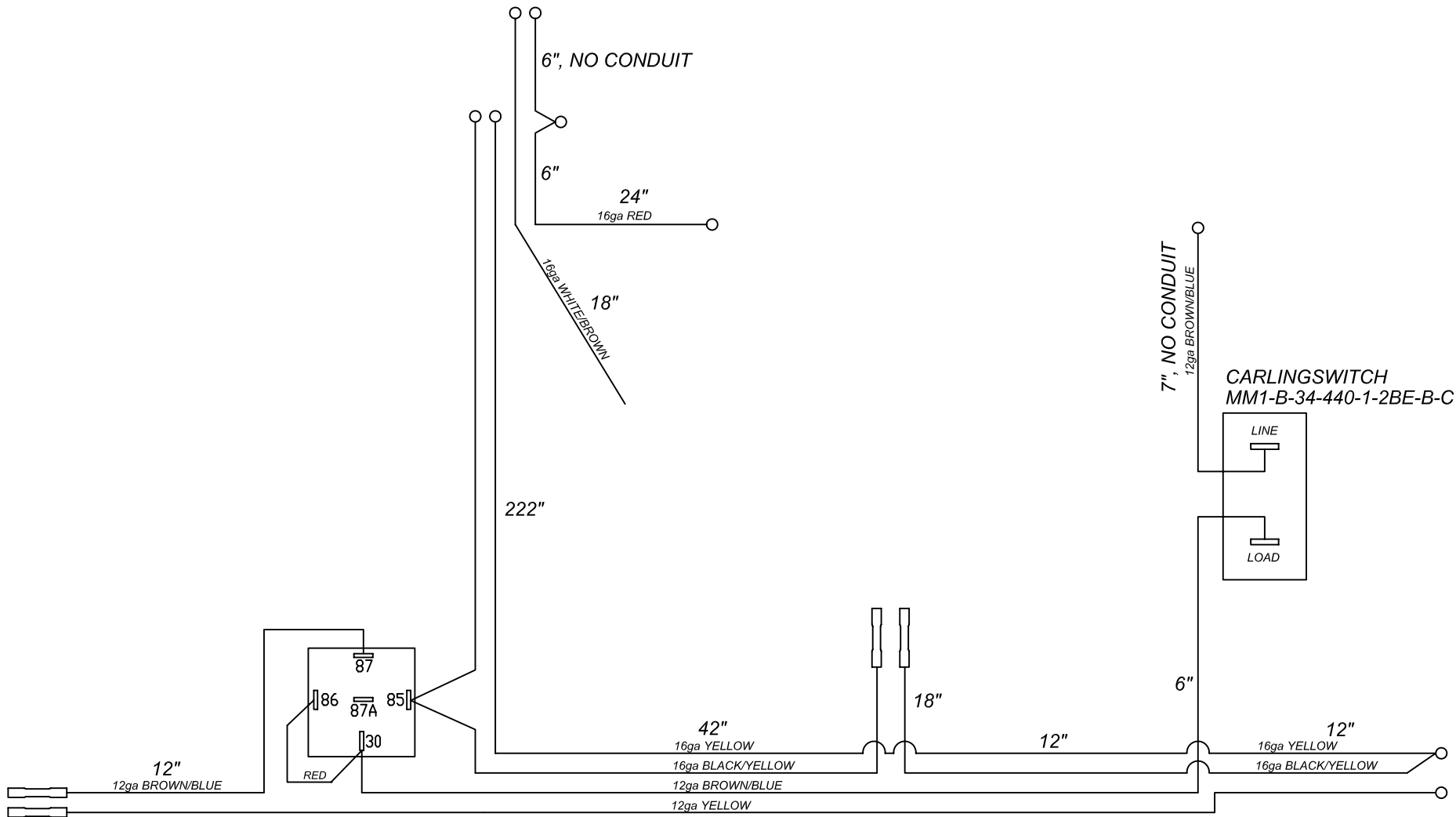

LEGEND
 ○ = #10 EYE
 ━━━ = BUTT SPLICE

NOTE: CONDUIT COMPLETELY EXCEPT AS NOTED

PROPRIETARY INFORMATION THIS DRAWING CONTAINS INFORMATION FOR WHICH HUNTER MARINE CORPORATION HAS PROPRIETARY RIGHTS.



| | | | |
|---|-------------------------------|----------------------|------------------------|
| DRAWING TITLE: <i>AUTOMATIC FIRE EXTINGUISHER OPTION</i> | | | |
| DRAWN BY: <i>JLK</i> | DATE: <i>28-Jul-04</i> | SHEET <i>1</i> | OF <i>1</i> |
| SCALE: <i>0.045</i> | HUNTER PART NO. <i>TBD</i> | REVISION <i>-</i> | DRAW # <i>-----</i> |

CHECKED

| WIRE# | GAUGE | COLOR | LENGTH | DESCRIPTION |
|-------|-------|--------------|--------|----------------|
| 61 | 10 | WHITE/GREEN | 144' | HW PUMP AUTO |
| 62 | 10 | WHITE/RED | 138' | HW PUMP MANUAL |
| 63 | 10 | YELLOW | 144' | HW PUMP NEG |
| 64 | 16 | YELLOW/BROWN | 210' | HW RELAY SW |
| 65 | 16 | BROWN/RED | 210' | HW ALARM IND |
| 66 | 16 | YELLOW | 216' | HW ALARM NEG |
| -- | 16 | RED | 2' | JUMPER |
| -- | 10 | WHITE/GREEN | 6' | JUMPER |
| -- | 10 | WHITE/GREEN | 7' | JUMPER |

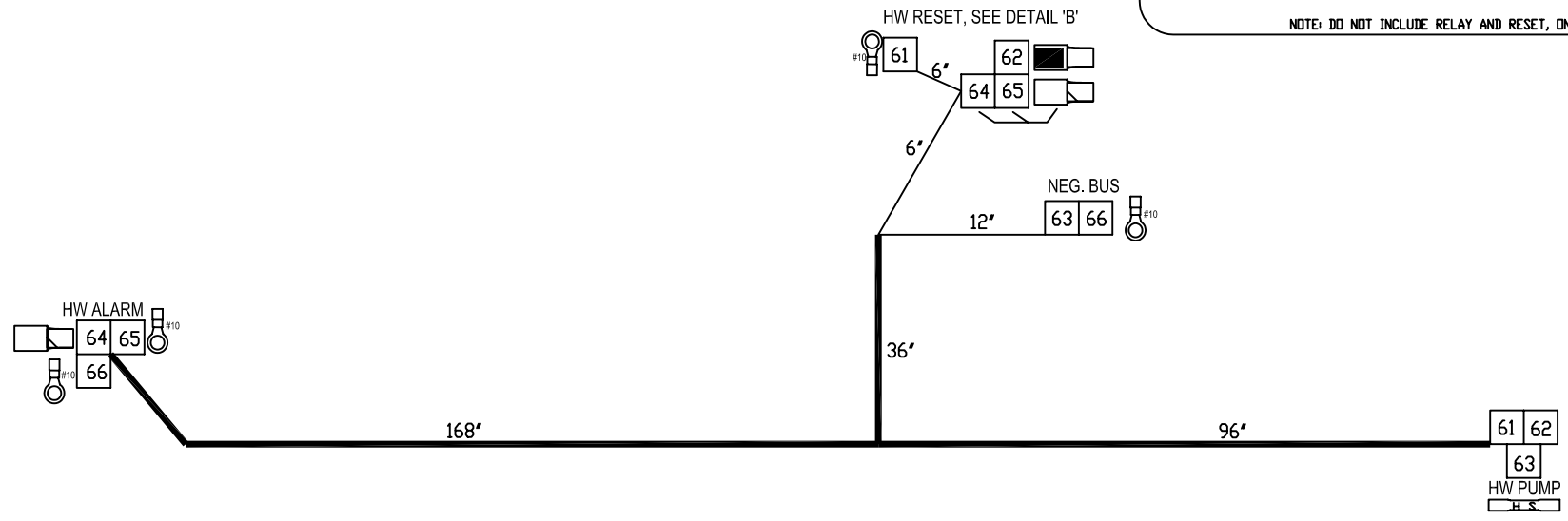
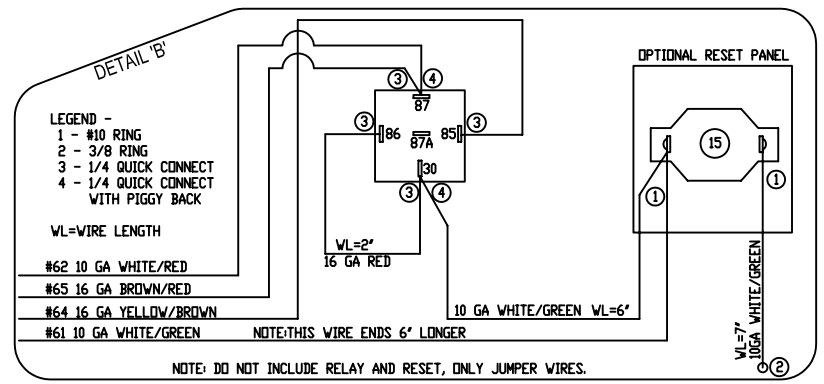

- = CONDUIT
- BARREL
- #10 RING
- 1/4" RING
- 5/16" RING
- 3/8 RING
- 1/4 SLIDE
- 1/4 SLIDE WPIGGYBACK

PROPRIETARY INFORMATION THIS DRAWING CONTAINS INFORMATION FOR WHICH HUNTER MARINE CORPORATION HAS PROPRIETARY RIGHTS.

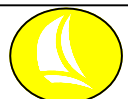

HUNTER 27

DRAWING TITLE:
HIGH WATER PUMP OPTION

| | | | |
|-------------------------|-----------------------------------|----------------------|---------------------------------|
| DRAWN BY: <i>JLK</i> | DATE: <i>7-Jul-04</i> | SHEET <i>1</i> | OF <i>1</i> |
| SCALE: <i>0.045</i> | HUNTER PART NO. <i>1013294</i> | REVISION <i>-</i> | DRAW # <i>drawing number</i> |

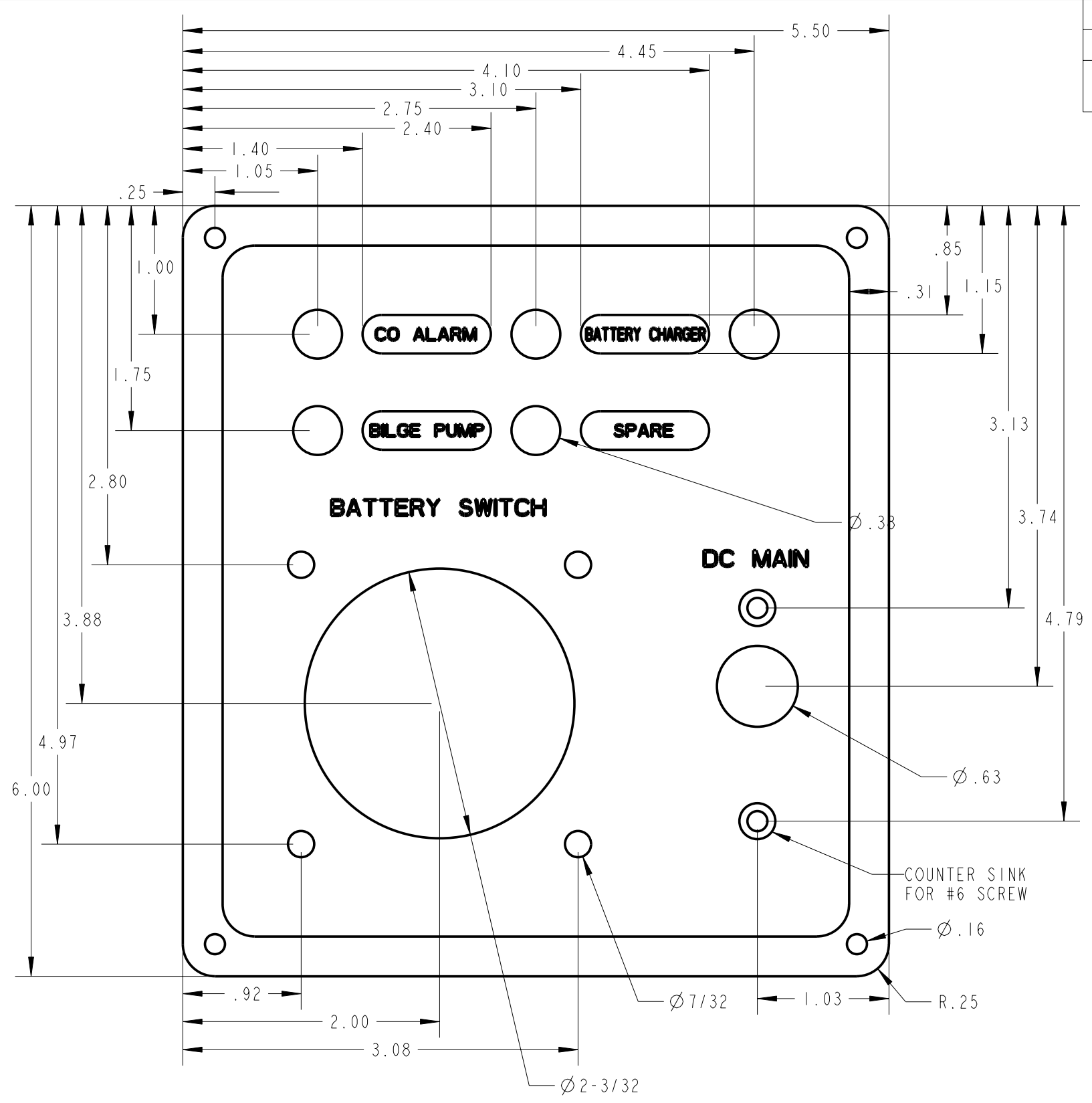

| SYMBOL | REVISIONS | DATE | ENG |
|--------|---|-----------|-----|
| A | MOVED SECOND ROW OF RESETS DOWN 1/8". | 7/27/2004 | JLK |
| B | UPDATE BATTERY SWITCH HOLES FOR BEP MODEL 701-S ALSO BATTERY CHARGER AND EXTRA HOLE | 4/12/2005 | JLK |

- NOTE:
- PANEL MATERIAL - 1/8" ALUMINUM
 - PANEL COLOR&FINISH - FLAT CARBON BLACK WITH GLOSSY BLACK BORDER
 - INSTALL THE FOLLOWING COMPONENTS:
 - BATTERY SWITCH, BEP #701-S
 - DC MAIN BREAKER, 40 AMPS
 - CO ALARM RESET, 5 AMPS
 - BILGE PUMP RESET, 5 AMPS
 - BATTERY CHARGER, 25 AMPS X2
 - SPARE, BLANK BLACK PLUG
 - PREWIRE COMPONENTS, SEE SCHEMATIC

PROPRIETARY INFORMATION: THIS DRAWING CONTAINS INFORMATION FOR WHICH HUNTER MARINE CORPORATION HAS PROPRIETARY RIGHTS.



| | | | |
|---|-------------------------------|-------------------|---|
| DRAWING TITLE: BATTERY SWITCH PANEL | | | |
| DRAWN BY: JLK | DATE: 25-May-04 | SHEET 1 | OF 1 |
| SCALE: 1.000 | HUNTER PART NO. TBD | REVISION | DRAW # H27.BATTERY SWITCH.PANEL |

CHECKED:

| SYMBOL | REVISIONS | DATE | ENG |
|--------|--|-----------|-----|
| B | DELETED PLUG 'E' AND WIRES TO IT. | 9/10/2004 | JLK |
| C | UPDATE BATTERY SWITCH TO DEP #701-S AND ADD BATTERY CHARGER RESETS | 4/12/2005 | JLK |

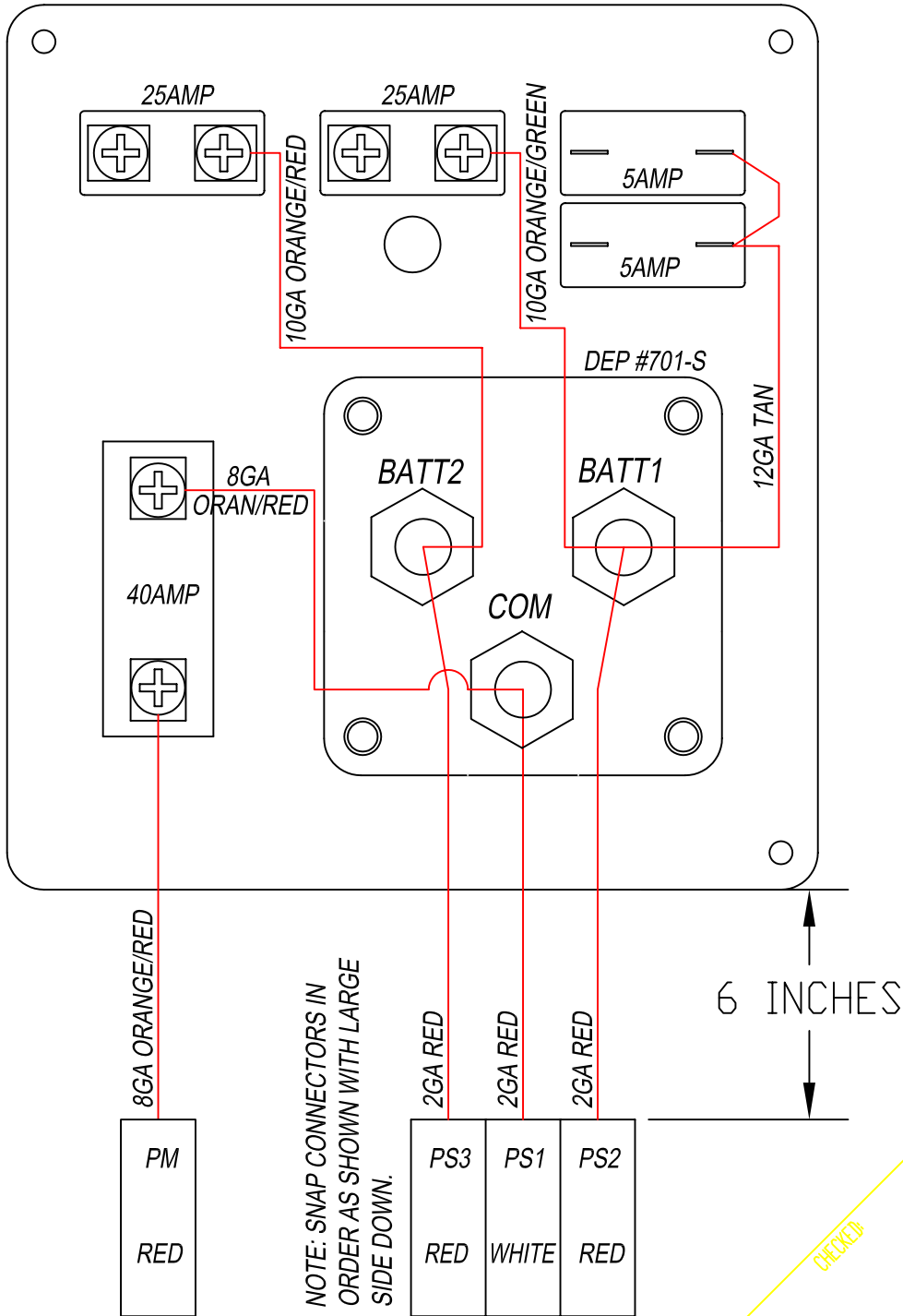

CONNECTOR LIST:

PM = POWERPOLE, PP75
RED HOUSING

PS1, 2&3 = POWERPOLE, PP120
WHITE HOUSING

PROPRIETARY INFORMATION: THIS DRAWING CONTAINS INFORMATION FOR WHICH HUNTER MARINE CORPORATION HAS PROPRIETARY RIGHTS.

HUNTER 27

DRAWING TITLE:
PANEL, BATTERY SWITCH SCHEMATIC

| | | | |
|-------------------------|-------------------------------|----------------------|---|
| DRAWN BY: JLK | DATE: 10-Sept-04 | SHEET 1 | OF 1 |
| SCALE: 0.750 | HUNTER PART NO. TBD | REVISION B | DRAW # H27_BATTERY_SW_PANEL_SCH |

| SYMBOL | REVISIONS | DATE | ENG |
|--------|-----------|------|-----|
| | | | |

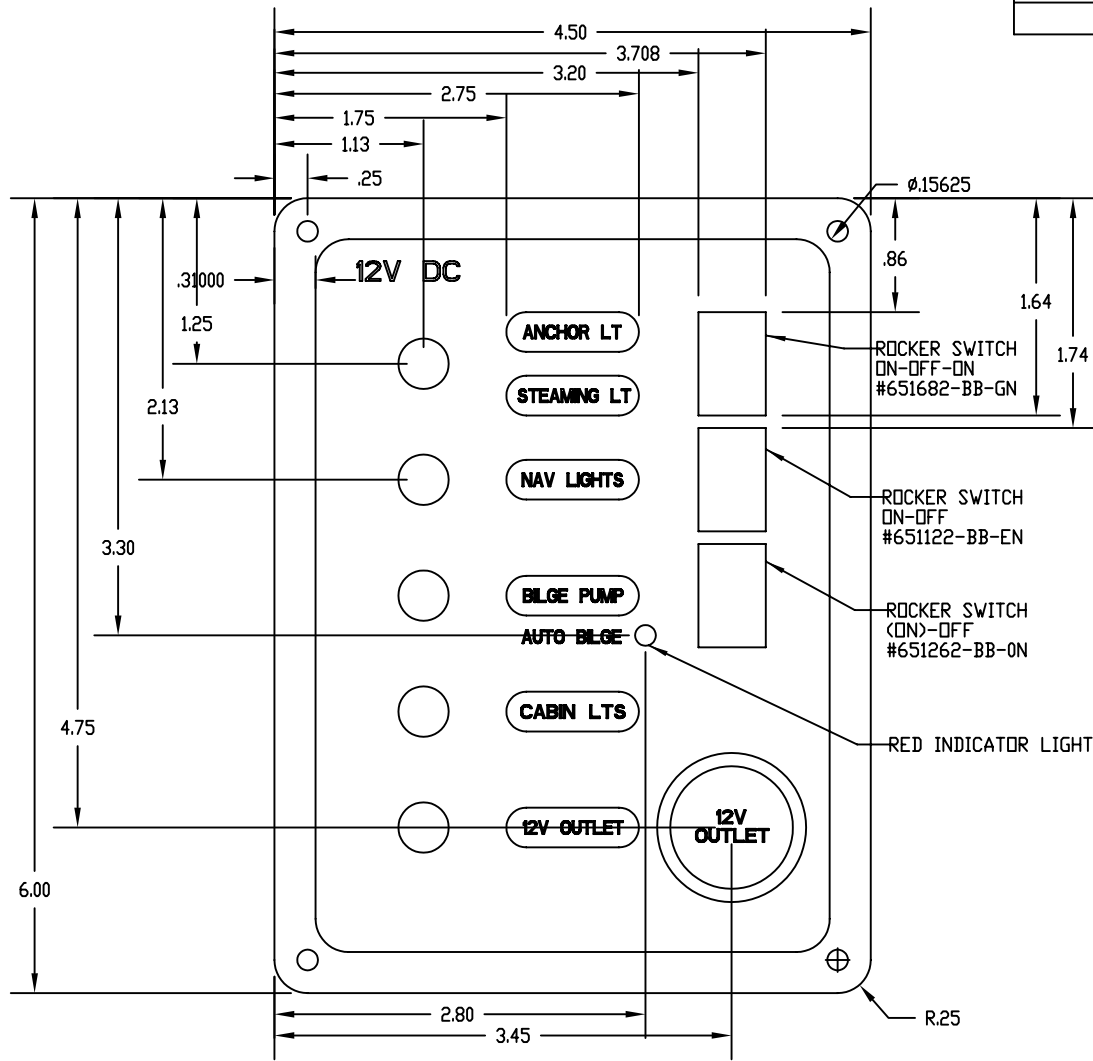

Ø.15625

.86

1.64

1.74

ROCKER SWITCH
ON-OFF-ON
#651682-BB-GN

ROCKER SWITCH
ON-OFF
#651122-BB-EN

ROCKER SWITCH
(ON)-OFF
#651262-BB-ON

RED INDICATOR LIGHT

R.25

NOTE:
1. PANEL MATERIAL - 1/8" ALUMINUM
2. PANEL COLOR&FINISH - FLAT CARBON BLACK WITH GLOSSY BLACK BORDER
3. CARLING SWITCHES.

RESET BREAKER LIST:
5 AMPS - ANCHOR/STEAMING LT
5 AMPS - NAV LIGHTS
5 AMPS - BILGE PUMP
10 AMPS - CABIN LIGHTS
15 AMPS - 12V OUTLETS

PROPRIETARY INFORMATION THIS DRAWING CONTAINS INFORMATION FOR WHICH HUNTER MARINE CORPORATION HAS PROPRIETARY RIGHTS



HUNTER 27

DRAWING TITLE: *PANEL, DC ONLY*

| | | |
|----------------------|----------------------------|---------------------------------|
| DRAWN BY: <i>JLK</i> | DATE: <i>24-May-04</i> | SHEET <i>1</i> OF <i>1</i> |
| SCALE: <i>1.000</i> | HUNTER PART NO. <i>TBD</i> | REVISION |
| | | DRAW # <i>H27_PANEL_DC_ONLY</i> |



HUNTER

27

DRAWING TITLE:

PANEL SCHEMATIC, DC ONLY

DRAWN BY:

JLK

DATE:

22-Jul-04

SHEET

1

OF

1

SCALE:

1.000

HUNTER PART NO.

TBD

REVISION

B

DRAW #

H27_PANEL_SCH_DC_ONLY

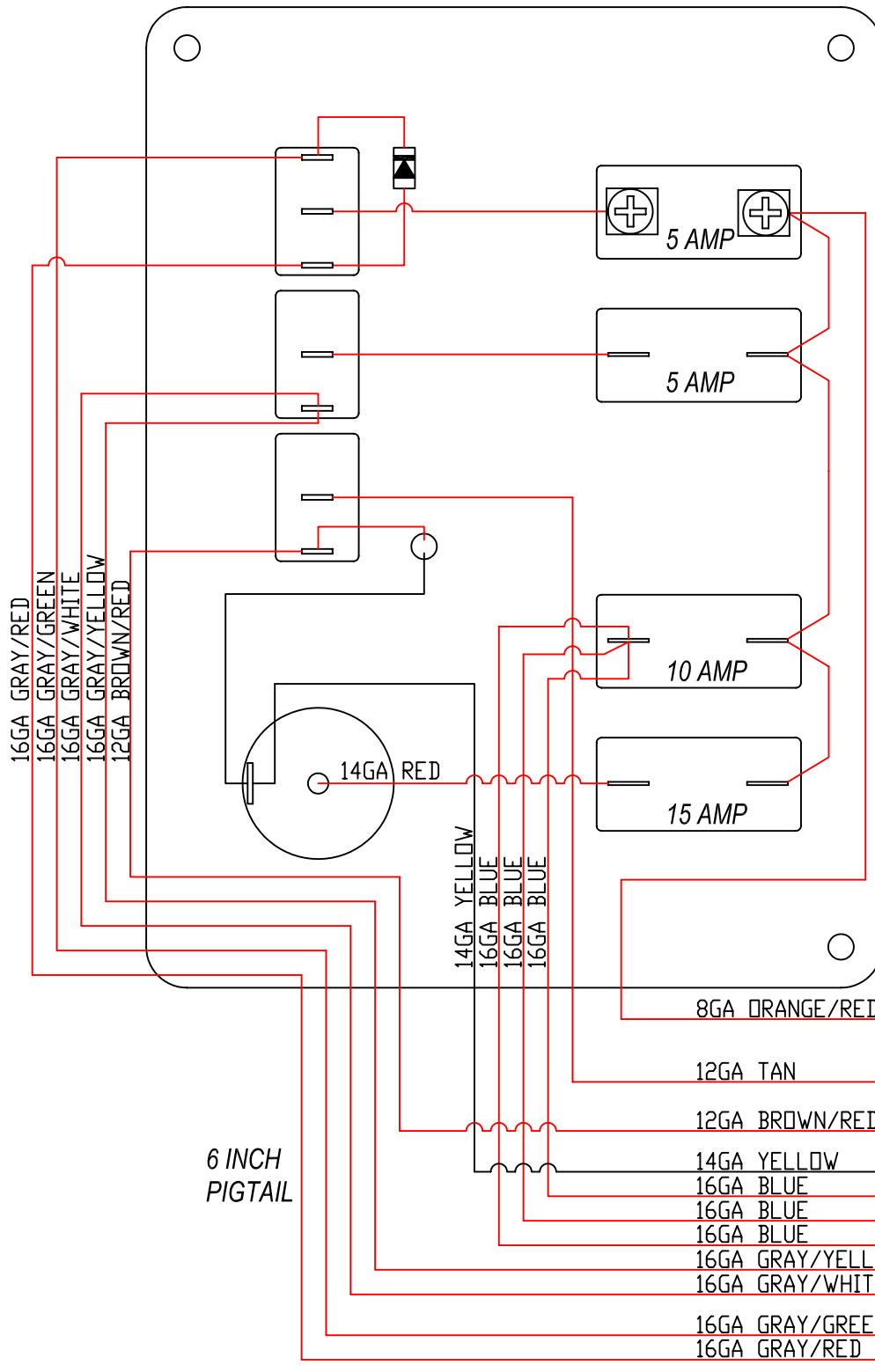

PP POWERPOLE, PP75

C4

C3

C2

C1

DEUTSCH DTP, MALE HOUSING W/FEMALE PINS

B6

B5

B4

B3

B2

B1

DEUTSCH DT, MALE HOUSING W/FEMALE PINS

A2

A1

DEUTSCH DT, MALE HOUSING W/FEMALE PINS

| SYMBOL | REVISIONS | DATE | ENG |
|--------|-----------|------|-----|
| | | | |

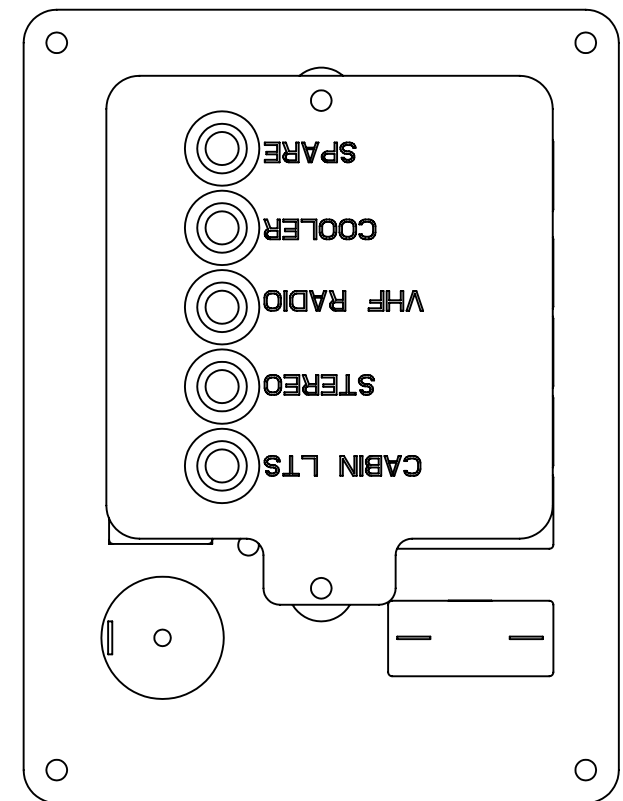
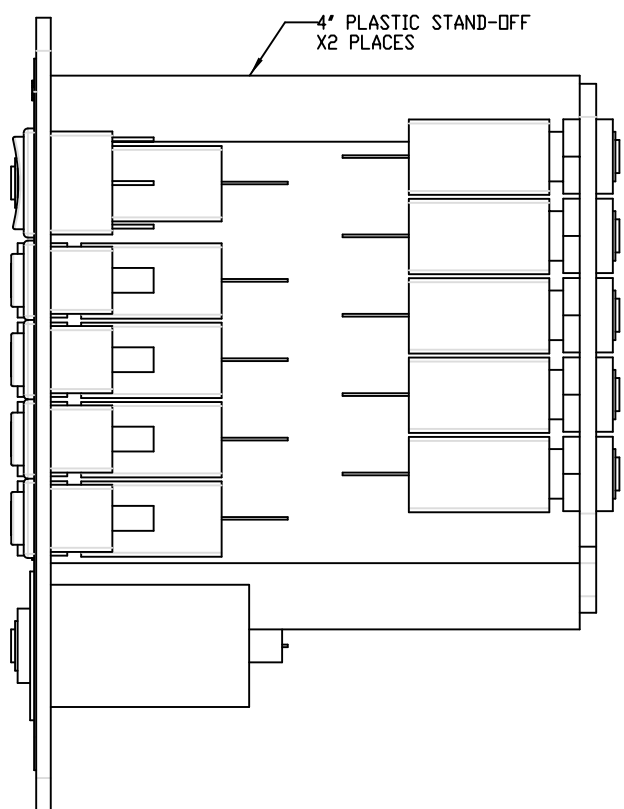
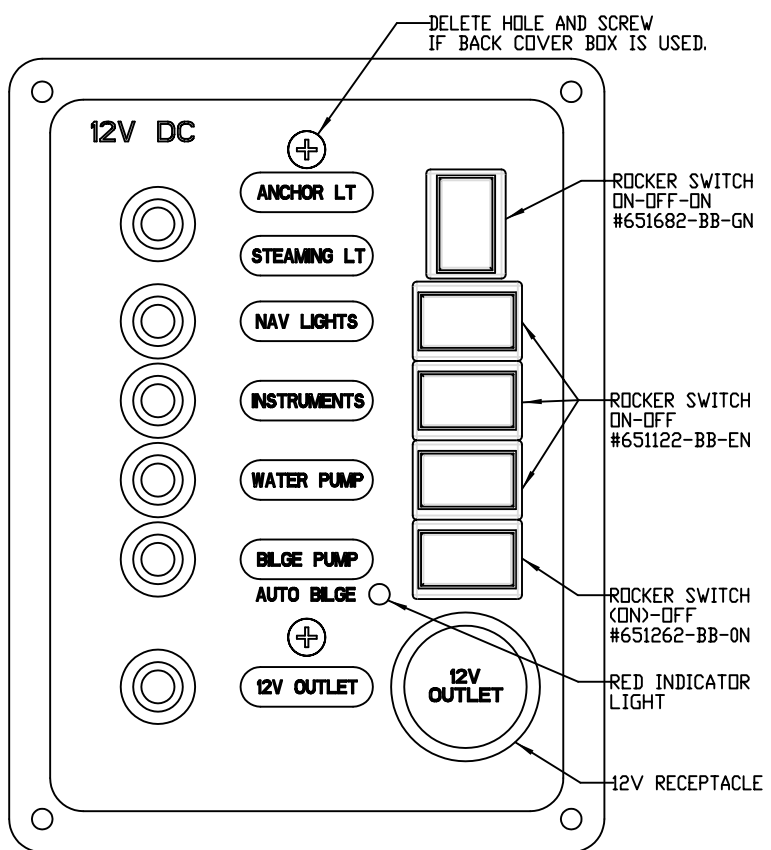

PROPRIETARY INFORMATION THIS DRAWING CONTAINS INFORMATION FOR WHICH HUNTER MARINE CORPORATION HAS PROPRIETARY RIGHTS

 HUNTER 27

DRAWING TITLE:
PANEL, DC DELUXE ASSEMBLY

| | | | |
|-------------------------|-------------------------------|-------------------|--------------------------------------|
| DRAWN BY: <i>JLK</i> | DATE: <i>04-Jun-04</i> | SHEET <i>2</i> | OF <i>2</i> |
| SCALE: <i>1.000</i> | HUNTER PART NO. <i>TBD</i> | REVISION | DRAW # <i>H27_DC_PANEL_DELUXE</i> |

CHECKED

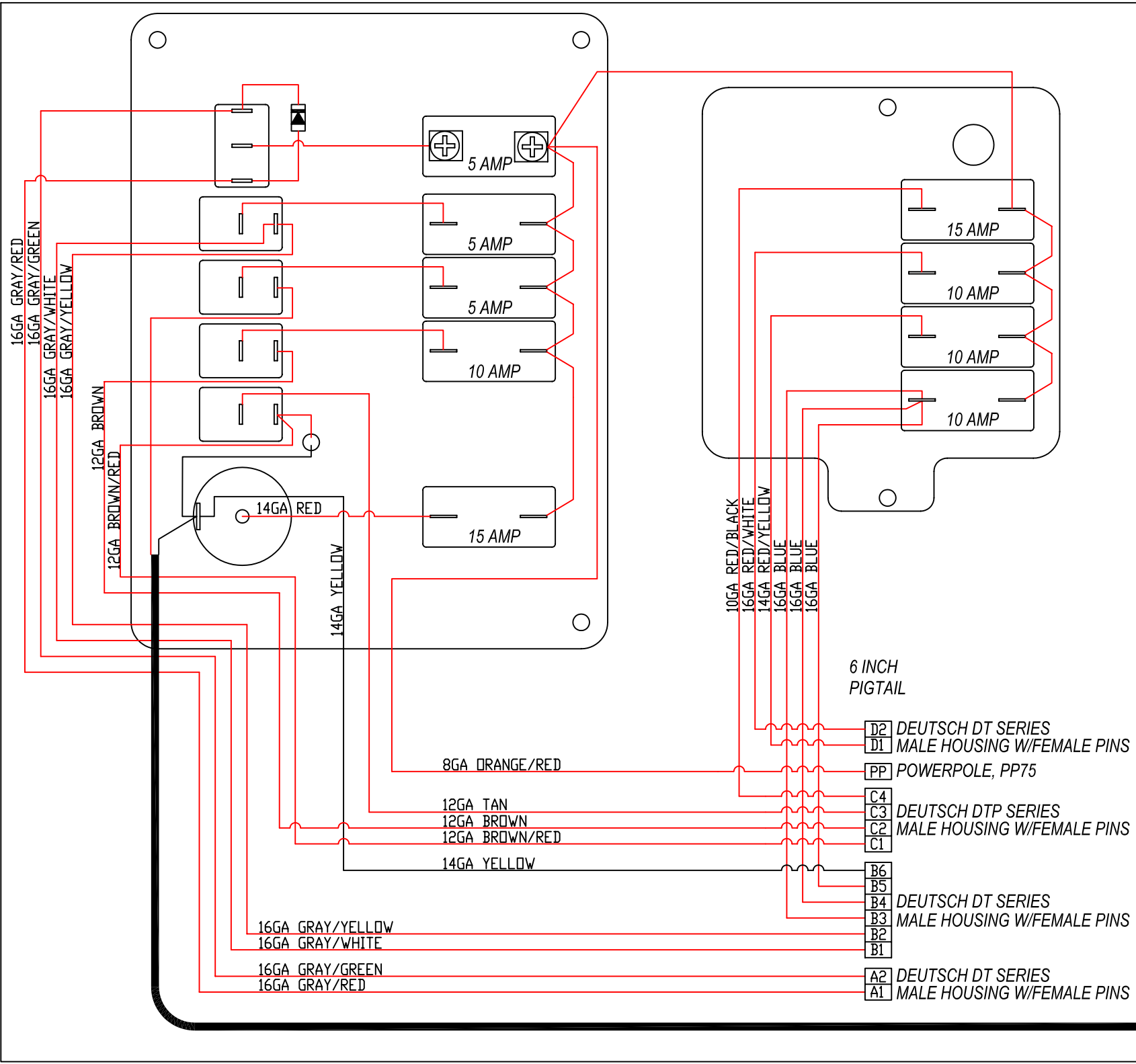

PROPRIETARY INFORMATION THIS DRAWING CONTAINS INFORMATION FOR WHICH HUNTER MARINE CORPORATION HAS PROPRIETARY RIGHTS

HUNTER

27

DRAWING TITLE: **PANEL SCHEMATIC, DELUXE VERSION**

| | | | |
|---------------|---------------------|-------------|--------------------------------|
| DRAWN BY: JLK | DATE: 27-Jan-05 | SHEET 1 | OF 1 |
| SCALE: 1.000 | HUNTER PART NO. TBD | REVISION: D | DRAW # H27_DC_PANEL_DELUXE_SCH |

24 INCHES LONG SEATALK CABLE

DC PANEL CONNECTORS for 27

All connectors to be female pins with male connectors.

6/4/2004

| CONN. A | WIRE# (HULL) | WIRED TO ON PANEL | CONN. TYPE |
|----------------|---------------------|--------------------------|-------------------------------|
| 1 | 16ga Gray/Red | ANCHOR LIGHT | Deutsch - DT Series - 2pin |
| 2 | 16ga Gray/Green | STEAMING LIGHT | |

| CONN. B | WIRE# (HULL) | WIRED TO ON PANEL | CONN. TYPE |
|----------------|---------------------|--------------------------|--------------------------------|
| 1 | 16ga Gray/White | BOW LIGHT | Deutsch - DT Series - 6 pin |
| 2 | 16ga Gray/Yellow | STERN LIGHT | |
| 3 | 16ga Blue | CABIN LIGHTS | |
| 4 | 16ga Blue | CABIN LIGHTS | |
| 5 | 16ga Blue | CABIN LIGHTS | |
| 6 | 14ga Yellow | 12V OUTLET NEG. | |

| CONN. C | WIRE# (HULL) | WIRED TO ON PANEL | CONN. TYPE |
|----------------|---------------------|--------------------------|--------------------------------|
| 1 | 12ga Brown/Red | BILGE PUMP | Deutsch - DTP Series - 4pin |
| 2 | 12ga Brown | WATER PUMP | |
| 3 | 10ga Brown/White | MACERATOR/SPARE | |
| 4 | 10ga Red/Black | COOLER | |

| CONN. D | WIRE# (HULL) | WIRED TO ON PANEL | CONN. TYPE |
|----------------|---------------------|--------------------------|-------------------------------|
| 1 | 14ga Red/Yellow | STEREO | Deutsch - DT Series - 2pin |
| 2 | 16ga Red/White | VHF RADIO | |

| CONN. PP | WIRE# (PANEL TO PANEL) | WIRED TO ON PANEL | CONN. TYPE |
|-----------------|-------------------------------|--------------------------|-------------------|
| 1 | 8ga Orange/Red | MAIN FEED | POWERPOLE PP75 |
| | | | |

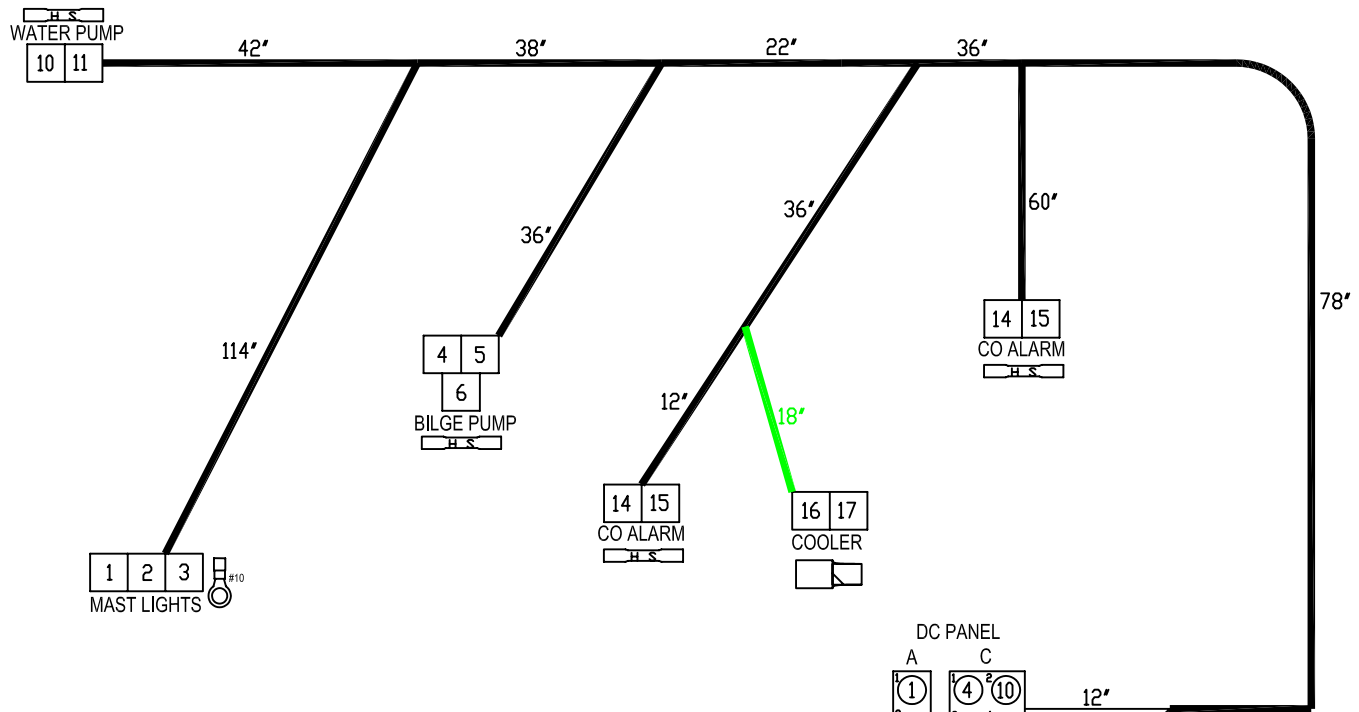

- A DEUTSCH DT SERIES FEMALE HOUSING W/MALE PINS
- C DEUTSCH DTP SERIES FEMALE HOUSING W/MALE PINS
- N DEUTSCH DT SERIES FEMALE HOUSING W/MALE PINS

UPDATED

- = CONDUIT
- BARREL
- #10 RING
- 1/4" RING
- 5/16" RING
- 3/8 RING
- 1/4 SLIDE
- 1/4 SLIDE WPIGGYBACK

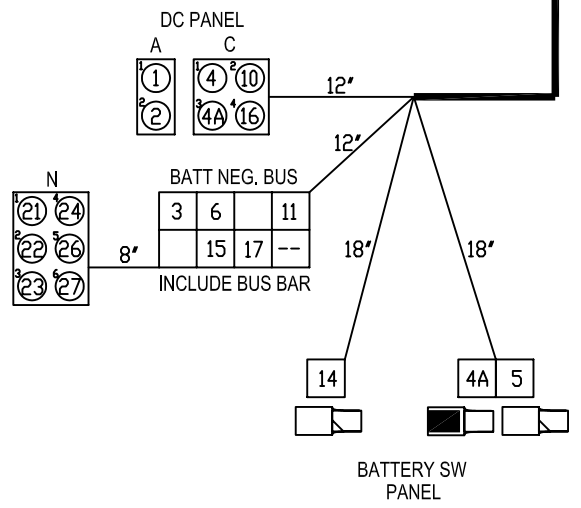

PROPRIETARY INFORMATION: THIS DRAWING CONTAINS INFORMATION FOR WHICH HUNTER MARINE CORPORATION HAS PROPRIETARY RIGHTS.

HUNTER

h27

DRAWING TITLE: HULL HARNESS

| | | | |
|--|--|---|--|
| DRAWN BY: JLK | DATE: 1-Nov-04 | SHEET 1 | OF 1 |
| SCALE: 0.045 | HUNTER PART NO. TBD | REVISION F | DRAW # drawing number |

| HUNTER 27 DC HULL HARNESS | | | | 1/27/2005 |
|---------------------------|-------|--------------|--------|-------------------|
| WIRE# | GAUGE | COLOR | LENGTH | FUNCTION |
| 1 | 16 | GRAY/RED | 300" | ANCHOR LIGHT |
| 2 | 16 | GRAY/GREEN | 300" | STEAMING LIGHT |
| 3 | 16 | YELLOW | 300" | MAST LIGHT GROUND |
| 4 | 12 | BROWN/RED | 184" | BILGE MANUAL SW |
| 4A | 12 | TAN | 30" | BILGE MANUAL SW |
| 5 | 12 | BROWN/ORANGE | 190" | BILGE AUTO |
| 6 | 12 | YELLOW | 184" | BILGE NEG. |
| 10 | 12 | BROWN | 228" | WATER PUMP |
| 11 | 12 | YELLOW | 228" | WATER PUMP NEG. |
| 14 | 16 | RED/BLUE | 300" | CO DETECTOR |
| 15 | 16 | YELLOW | 294" | CO DETECTOR NEG. |
| 16 | 10 | RED/BLACK | 180" | COOLER |
| 17 | 10 | YELLOW | 180" | COOLER NEG. |
| 21 | 14 | YELLOW | 8" | 12V OUTLET NEG. |
| 22 | 16 | YELLOW | 8" | CABIN LTS NEG. |
| 23 | 16 | YELLOW | 8" | CABIN LTS NEG. |
| 24 | 16 | YELLOW | 8" | CABIN LTS NEG. |
| 26 | 16 | YELLOW | 8" | BOW LT NEG. |
| 27 | 16 | YELLOW | 8" | STERN LT NEG. |

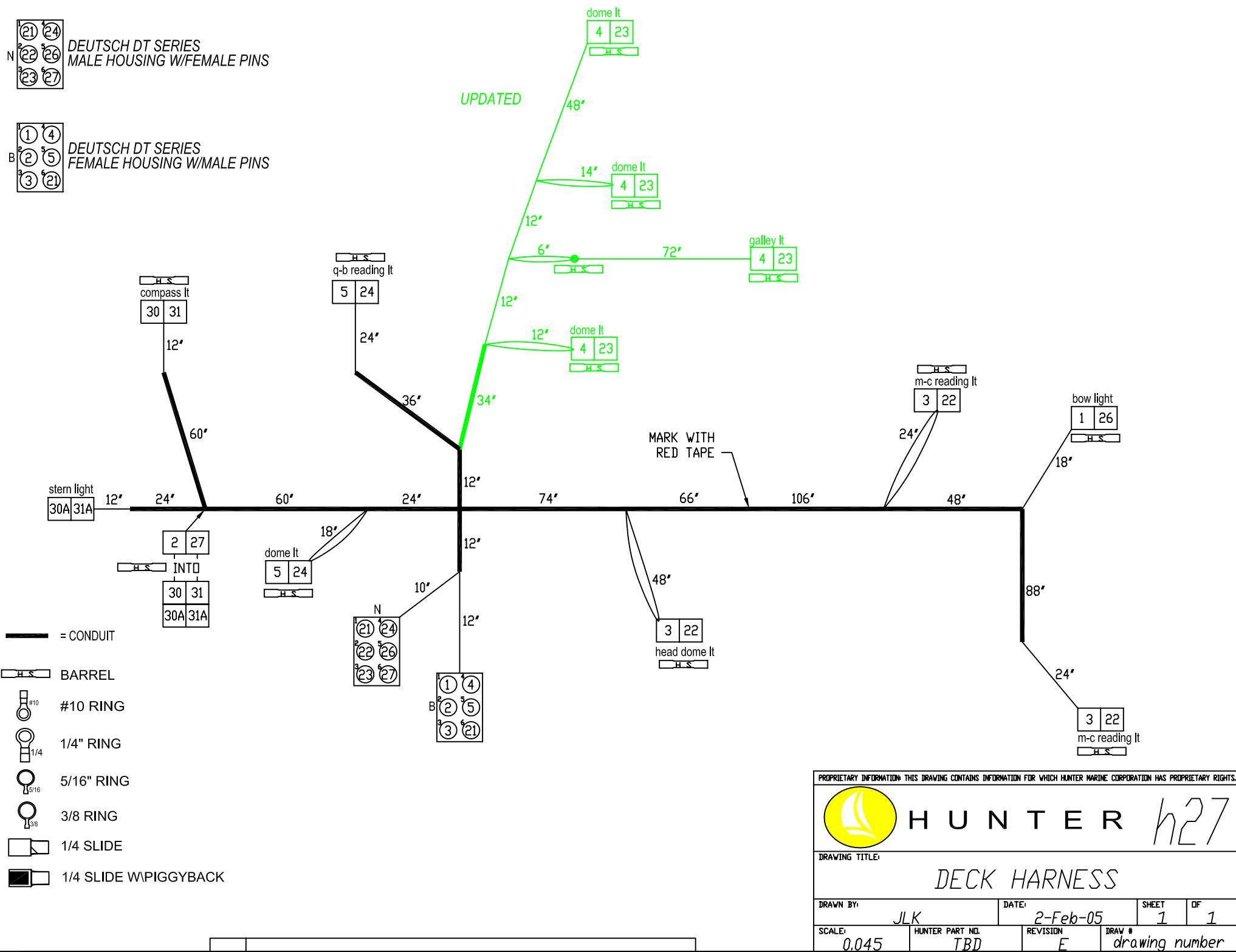

PROPRIETARY INFORMATION: THIS DRAWING CONTAINS INFORMATION FOR WHICH HUNTER MARINE CORPORATION HAS PROPRIETARY RIGHTS.

HUNTER *h27*







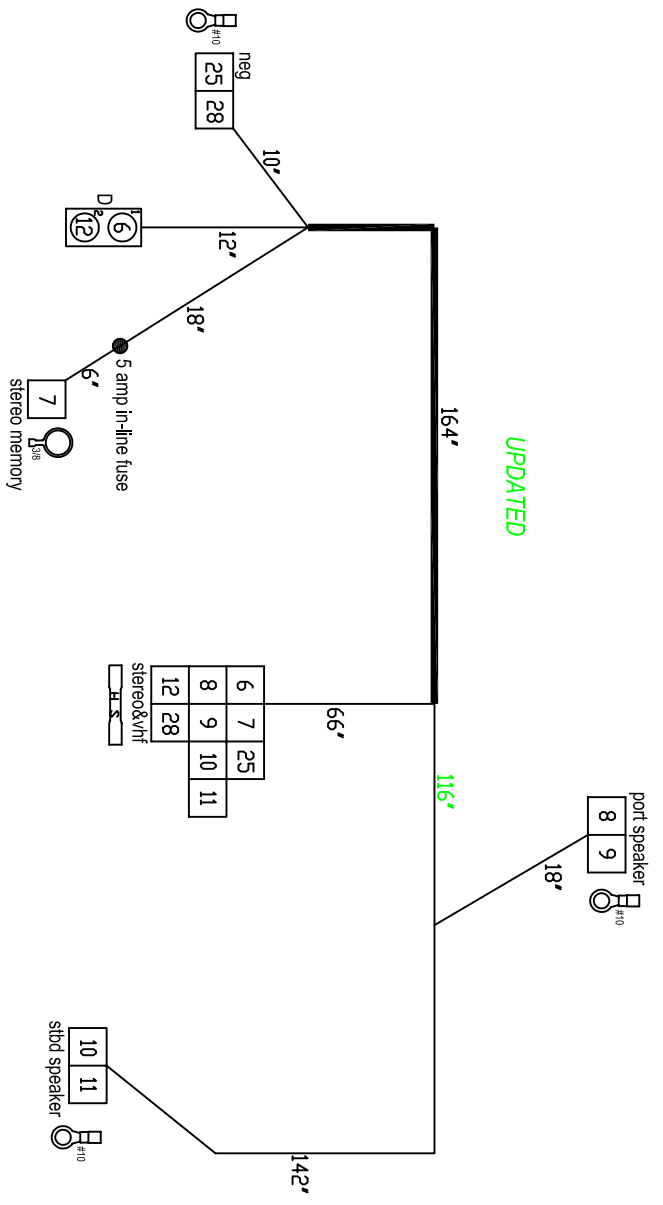

DRAWING TITLE: **DECK HARNESS**

| | | | |
|----------------------|----------------------------|-------------------|------------------------------|
| DRAWN BY: <i>JLK</i> | DATE: <i>2-Feb-05</i> | SHEET <i>1</i> | OF <i>1</i> |
| SCALE: <i>0.045</i> | HUNTER PART NO. <i>TBD</i> | REVISION <i>E</i> | DRAW # <i>drawing number</i> |



DEUTSCH DT SERIES
FEMALE HOUSING W/MALE PINS



#29 SHORE POWER 18 Feet

-  = CONDUIT
-  BARREL
-  #10 RING
-  1/4" RING
-  5/16" RING
-  3/8 RING
-  1/4 SLIDE
-  1/4 SLIDE W/PIGGYBACK

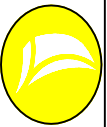
PROPRIETARY INFORMATION THIS DRAWING CONTAINS INFORMATION FOR WHICH HUNTER MARINE CORPORATION HAS PROPRIETARY RIGHTS.



HUNTER

h27

DRAWING TITLE: **OPTIONAL DECK HARNESS**

DRAWN BY: **JLK** DATE: **6-Dec-04** SHEET **1** OF **1**
 HUNTER PART NO. **TBD** REVISION **C** DRAW # **drawing number**

SCALE: **0.045**

| HUNTER 27 DC DECK HARNESS | | | | 2/2/2005 |
|---------------------------|-------|--------------|--------|-----------------------|
| WIRE# | GAUGE | COLOR | LENGTH | FUNCTION |
| 1 | 16 | GRAY/WHITE | 336" | BOW LIGHT |
| 2 | 16 | GRAY/YELLOW | 108" | STERN/COMPASS LIGHT |
| 3 | 16 | BLUE | 574" | PORT&FWD LIGHTS |
| 4 | 16 | BLUE | 278" | MAIN CABIN LIGHTS |
| 5 | 16 | BLUE | 180" | AFT CABIN LIGHTS |
| 6 | 14 | RED/YELLOW | 242" | STEREO |
| 7 | 14 | YELLOW/RED | 254" | STEREO MEMORY |
| 8 | 16 | WHITE/ORANGE | 200" | SPEAKER LEFT (+) |
| 9 | 16 | WHITE/YELLOW | 200" | SPEAKER LEFT (-) |
| 10 | 16 | WHITE/BLUE | 324" | SPEAKER RIGHT (+) |
| 11 | 16 | WHITE/BLACK | 324" | SPEAKER RIGHT (-) |
| 12 | 16 | RED/WHITE | 242" | VHF RADIO |
| 21 | 14 | YELLOW | 22" | 12V OUTLET NEG. |
| 22 | 16 | YELLOW | 572" | PORT&FWD LTS NEG. |
| 23 | 16 | YELLOW | 276" | MAIN CABIN LTS NEG. |
| 24 | 16 | YELLOW | 178" | AFT CABIN LTS NEG. |
| 25 | 14 | YELLOW | 242" | STEREO NEG. |
| 26 | 16 | YELLOW | 334" | BOW LT NEG. |
| 27 | 16 | YELLOW | 106" | STERN/COMPASS LT NEG. |
| 28 | 16 | YELLOW | 242" | VHF RADIO NEG. |
| 29 | 10/3 | ROMEX | 216" | SHORE POWER |
| 30 | 16 | GRAY/YELLOW | 72" | COMPASS LT |
| 30A | 16 | GRAY/YELLOW | 36" | STERN LT |
| 31 | 16 | YELLOW | 72" | COMPASS LT NEG. |
| 31A | 16 | YELLOW | 36" | STERN LT NEG. |

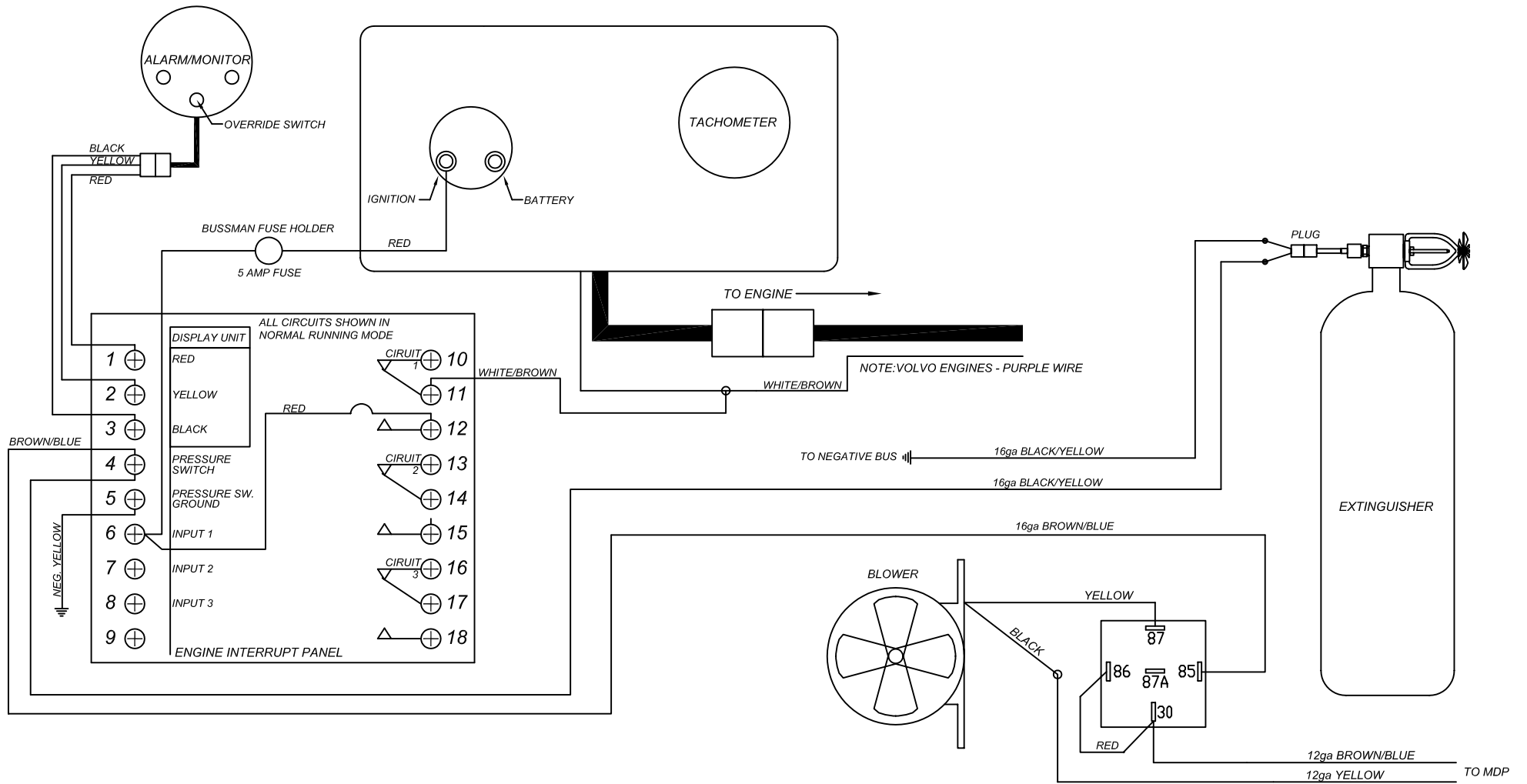

PROPRIETARY INFORMATION THIS DRAWING CONTAINS INFORMATION FOR WHICH HUNTER MARINE CORPORATION HAS PROPRIETARY RIGHTS.

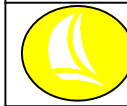

HUNTER 27/30/33

| | | | |
|--|------------------------|---------------|-----------------|
| DRAWING TITLE: AUTOMATIC FIRE EXTINGUISHER SCHEMATIC | | | |
| DRAWN BY: JLK | DATE: 4-Feb-05 | SHEET 1 | OF 1 |
| SCALE: 0.045 | HUNTER PART NO. TBD | REVISION A | DRAW # ----- |

CHECKED

| SYMBOL | REVISIONS | DATE | ENG |
|--------|-----------------------------------|-----------|-----|
| A | CHANGE TERMINALS ON AUDIBLE ALARM | 7/21/2003 | JLK |

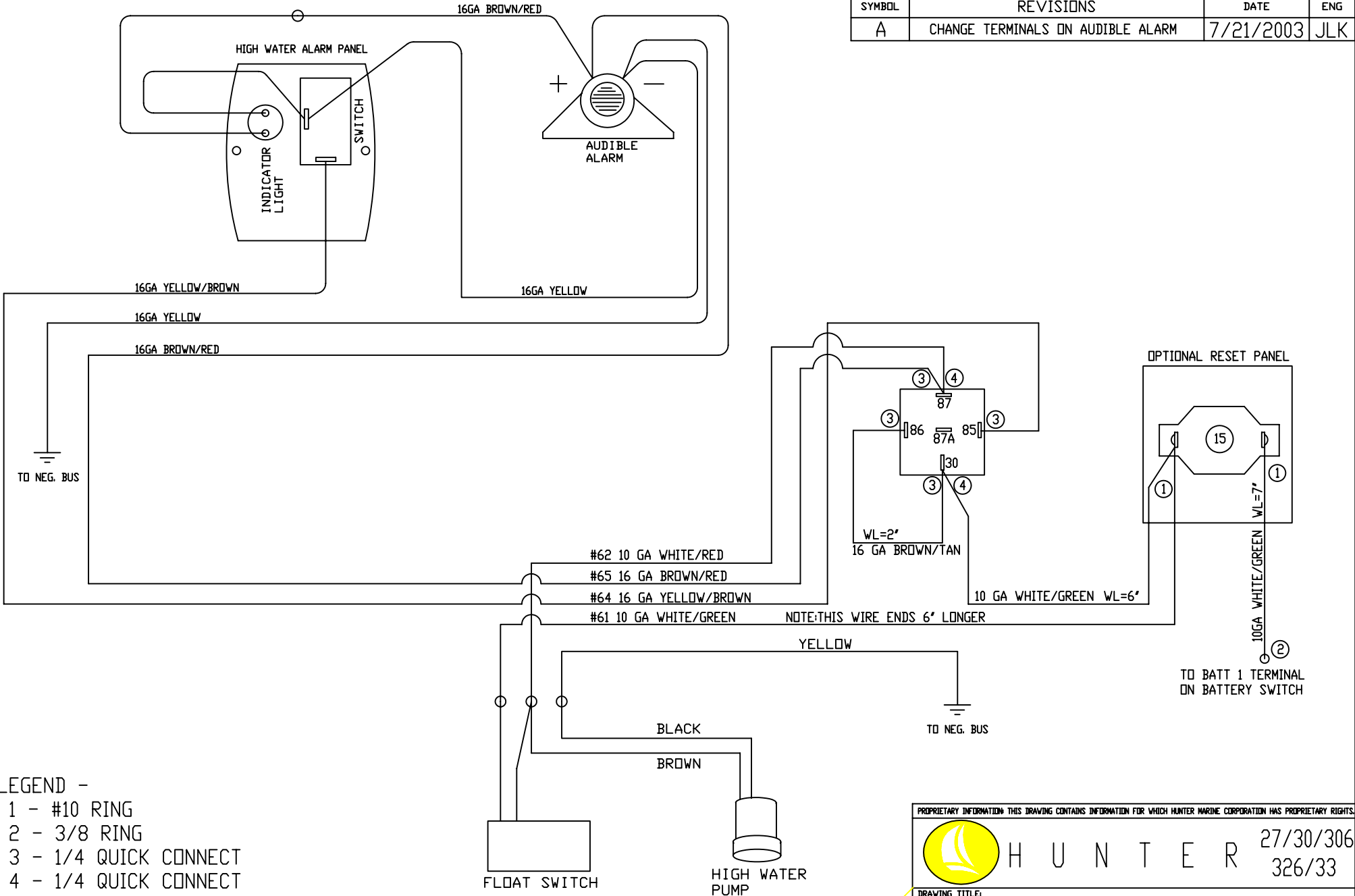

LEGEND -
 1 - #10 RING
 2 - 3/8 RING
 3 - 1/4 QUICK CONNECT
 4 - 1/4 QUICK CONNECT WITH PIGGY BACK

WL=WIRE LENGTH

PROPRIETARY INFORMATION: THIS DRAWING CONTAINS INFORMATION FOR WHICH HUNTER MARINE CORPORATION HAS PROPRIETARY RIGHTS.

 H U N T E R 27/30/306
326/33

DRAWING TITLE:
HIGH WATER BILGE PUMP SCHEMATIC

| | | | |
|------------------|--------------------|----------|--------|
| DRAWN BY: JLK | DATE: 2/27/2003 | SHEET | OF |
| SCALE: | HUNTER PART NO. | REVISION | DRAW # |

CHECKED