

NOTE: CONDUIT ALL HARNESSES COMPLETELY

REV. 9/25/2007

45DS AC WIRES

USE MOLEX SC FOR WIRE CIRCUITS LISTED BELOW EXCEPT AS NOTED

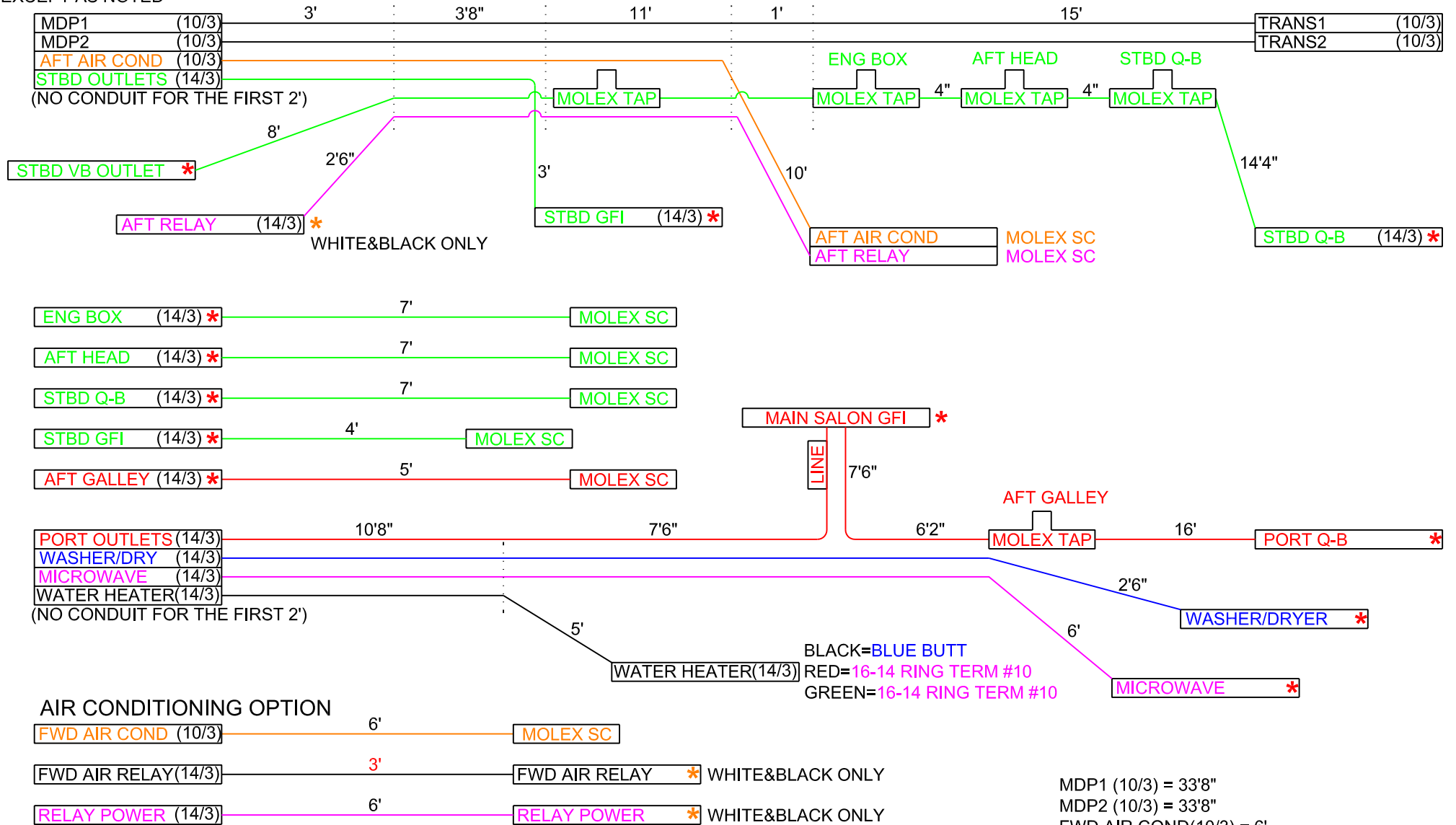

LEGEND:

- * = 16-14 CAPTIVE SPADE #8
- * = 12-10 CAPTIVE SPADE #8
- * = 16-14 RING TERM. #10
- * = 12-10 RING TERM. #10
- * = 12-10 RING TERM. 1/4"
- * = 16-14 1/4" QUICK CONNECT
- MOLEX SC #19403-1011 FOR 14/3 AND 16/3
- MOLEX SC #19403-1300 FOR 10/3
- MOLEX TAP #19402-1011

- MDP1 (10/3) = 33'8"
- MDP2 (10/3) = 33'8"
- FWD AIR COND(10/3) = 6'
- AFT AIR COND(10/3) = 27'8"
- FWD AIR RELAY(14/3) = 3'
- AFT AIR RELAY(14/3) = 27'2"
- PUMP RELAY(14/3) = 6'
- MICROWAVE(14/3) = 30'4"
- WATER HEATER(14/3) = 15'8"
- WASHER/DRYER(14/3) = 26'10"
- PORT OUTLETS (14/3) = 55'4"+5'
- STBD OUTLETS (14/3) = 9'8"+38'8"+7'+7'+4'